

**ADC12030,ADC12032,ADC12034,ADC12038,  
ADC12H030,ADC12H032,ADC12H034,ADC12H038**

*ADC12H030/ADC12H032/ADC12H034/ADC12H038,*

*ADC12030/ADC12032/ADC12034/ADC12038 Self-Calibrating 12-Bit Plus Sign  
Serial I/O A/D Converters with MUX and Sample/Hold*



Literature Number: SNAS080J

# ADC12H030/ADC12H032/ADC12H034/ADC12H038, ADC12030/ADC12032/ADC12034/ADC12038 Self-Calibrating 12-Bit Plus Sign Serial I/O A/D Converters with MUX and Sample/Hold

## General Description

**NOTE: Some of these devices may be obsolete and are described and shown here for reference only. See our web site for product availability.**

The ADC12030, and ADC12H030 families are 12-bit plus sign successive approximation Analog-to-Digital Converters with serial I/O and configurable input multiplexers. The ADC12034/ADC12H034 and ADC12038/ADC12H038 have 4 and 8 channel multiplexers, respectively. The differential multiplexer outputs and ADC inputs are available on the MUX-OUT1, MUXOUT2, A/DIN1 and A/DIN2 pins. The ADC12030/ADC12H030 has a two channel multiplexer with the multiplexer outputs and ADC inputs internally connected. The ADC12030 family is tested with a 5 MHz clock, while the ADC12H030 family is tested with an 8 MHz clock. On request, these ADCs go through a self calibration process that adjusts linearity, zero and full-scale errors to less than  $\pm 1$  LSB each.

The analog inputs can be configured to operate in various combinations of single-ended, differential, or pseudo-differential modes. A fully differential unipolar analog input range (0V to +5V) can be accommodated with a single +5V supply. In the differential modes, valid outputs are obtained even when the negative inputs are greater than the positive because of the 12-bit plus sign output data format.

The serial I/O is configured to comply with NSC MICROWIRE. For voltage references see the LM4040, LM4050 or LM4041.

## Features

- Serial I/O (MICROWIRE Compatible)
- 2, 4, or 8 chan differential or single-ended multiplexer
- Analog input sample/hold function
- Power down mode
- Variable resolution and conversion rate
- Programmable acquisition time
- Variable digital output word length and format
- No zero or full scale adjustment required
- Fully tested and guaranteed with a 4.096V reference
- 0V to 5V analog input range with single 5V power supply
- No Missing Codes over temperature

## Key Specifications

|                                    |                   |
|------------------------------------|-------------------|
| ■ Resolution                       | 12-bit plus sign  |
| ■ 12-bit plus sign conversion time |                   |
| – ADC12H30 family                  | 5.5 $\mu$ s (max) |
| – ADC12030 family                  | 8.8 $\mu$ s (max) |
| ■ 12-bit plus sign throughput time |                   |
| – ADC12H30 family                  | 8.6 $\mu$ s (max) |
| – ADC12030 family                  | 14 $\mu$ s (max)  |
| ■ Integral Linearity Error         | $\pm 1$ LSB (max) |
| ■ Single Supply                    | 5V $\pm 10\%$     |
| ■ Power consumption                | 33 mW (max)       |
| – Power down                       | 100 $\mu$ W (typ) |

## Applications

- Medical instruments
- Process control systems
- Test equipment

## ADC12038 Simplified Block Diagram

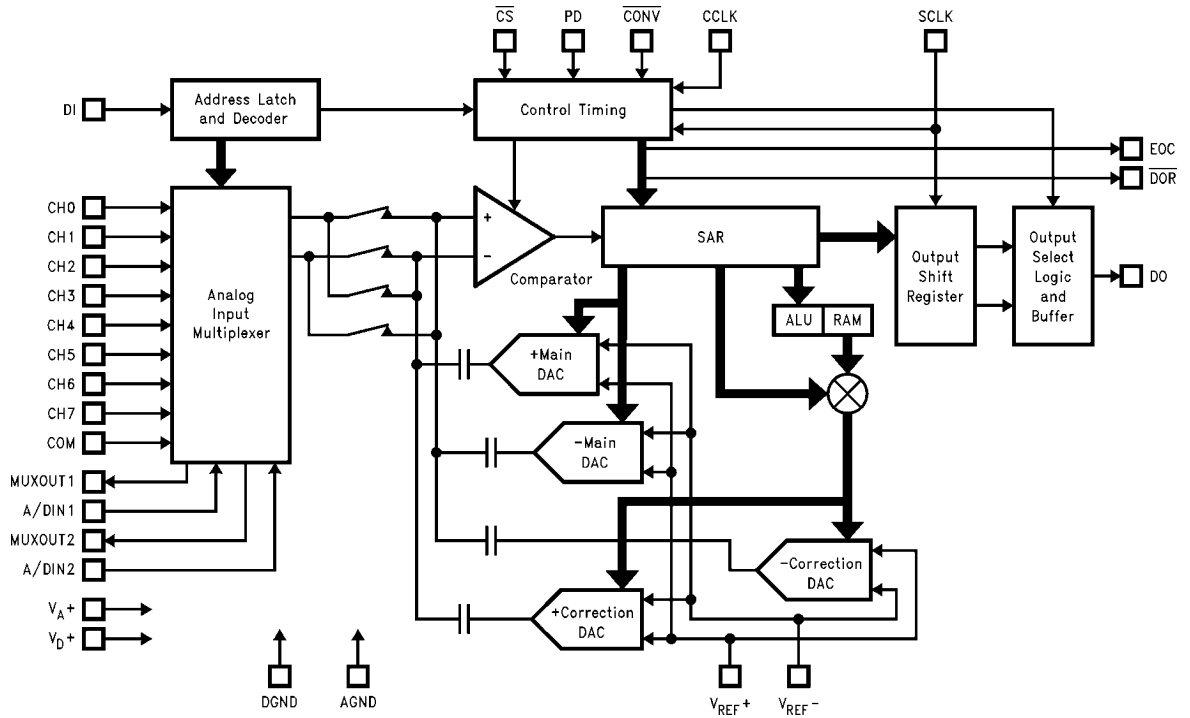

1135401

## Connection Diagrams

**16-Pin Wide Body SO Packages**

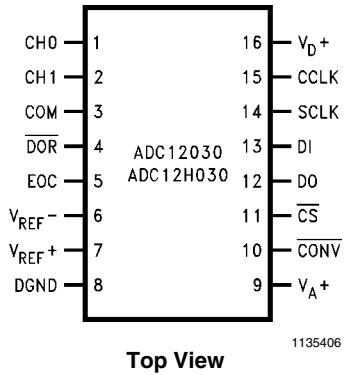

**20-Pin Wide Body SO Packages**

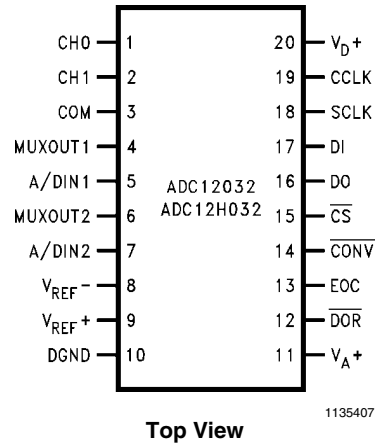

**24-Pin Wide Body  
SO, DIP, SSOP-EIAJ Packages**

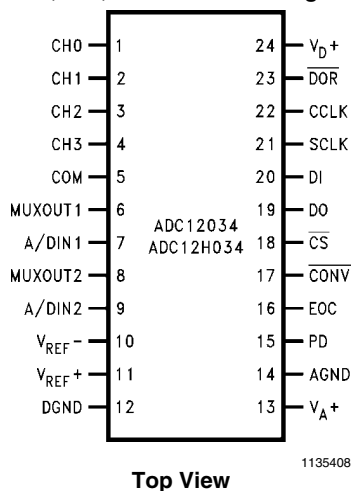

Top View

**28-Pin Wide Body  
SO Packages**

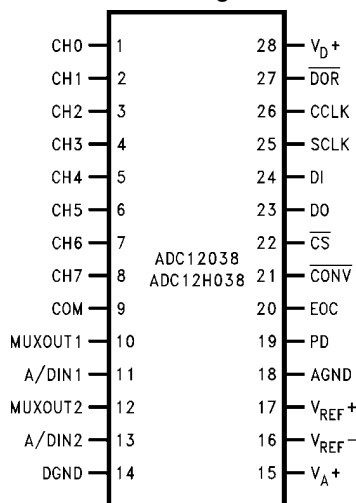

Top View

**Ordering Information**

| Industrial Temperature Range<br>-40°C ≤ T <sub>A</sub> ≤ +85°C | Package                          |
|--|----------------------------------|
| ADC12H030CIWM,<br>ADC12030CIWM                                 | M16B, Wide Body SO               |
| ADC12030CIWMX  | M16B, Wide Body SO - Tape & Reel |
| ADC12032CIWM   | M20B, Wide Body SO               |
| ADC12034CIN  | N24C, Dual-In-Line               |
| ADC12034CIWM   | M24B, Wide Body SO               |
| ADC12H034CIMSAX  | MSA24, SSOP                      |
| ADC12H034CIMSAX  | MSA24, SSOP - Tape & Reel        |
| ADC12H038CIWM,<br>ADC12038CIWM                                 | M28B, Wide Body SO               |
| ADC12H038CIWMX,<br>ADC12038CIWMX                               | M28B, Wide Body SO - Tape & Reel |

**Pin Descriptions**

| Pin Name           | pin Description  |
|--------------------|--|
| CH0 thru CH7       | Analog Inputs to the MUX (multiplexer). A channel input is selected by the address information at the DI pin, which is loaded on the rising edge of SCLK into the address register (See <i>Tables 2, 3, 4</i> ). The voltage applied to these inputs should not exceed V <sub>A+</sub> or go below V <sub>A-</sub> or below GND. Exceeding this range on an unselected channel may corrupt the reading of a selected channel.                              |
| COM                | Analog input pin that is used as a pseudo ground when the analog multiplexer is single-ended.  |
| MUXOUT1<br>MUXOUT2 | Multiplexer Output pins. If the multiplexer is used, these pins should be connected to the A/DIN pins, directly or through an amplifier and/of filter.   |
| A/DIN1<br>A/DIN2   | Converter Input pins. MUXOUT1 is usually tied to A/DIN1. MUXOUT2 is usually tied to A/DIN2. If external circuitry is placed between MUXOUT1 and A/DIN1, or MUXOUT2 and A/DIN2, it may be necessary to protect these pins against voltage overload. The voltage at these pins should not exceed V <sub>A+</sub> or go below AGND (see <i>Figure 6</i> ).  |
| DO                 | Data Output pin. This pin is an active push/pull output when CS is low. When CS is high, this output is TRI-STATE®. The conversion result (D0–D12) and converter status data are clocked out by the falling edge of SCLK on this pin. The word length and format of this result can vary (see <i>Table 1</i> ). The word length and format are controlled by the data shifted into the multiplexer address and mode select register (see <i>Table 5</i> ). |

| Pin Name                             | pin Description   |
|--------------------------------------|---|
| DI                                   | Serial Data input pin. The data applied to this pin is shifted by the rising edge of SCLK into the multiplexer address and mode select register. <i>Table 2</i> through <i>Table 5</i> show the assignment of the multiplexer address and the mode select data.   |
| EOC                                  | This pin is an active push/pull output which indicates the status of the ADC12030/2/4/8. A logic low on this pin indicates that the ADC is busy with a conversion, Auto Calibration, Auto Zero or power down cycle. The rising edge of EOC signals the end of one of these cycles.  |
| $\overline{\text{CONV}}$             | A logic low is required at this pin to program any mode or to change the ADC's configuration as listed in Mode Programming <i>Table 5</i> . When this pin is high, the ADC is placed in the read data only mode. While in the read data only mode, bringing $\overline{\text{CS}}$ low and pulsing SCLK will only clock out the data stored in the ADCs output shift register. The data on DI will be neglected. A new conversion will not be started and the ADC will remain in the mode and/or configuration previously programmed. Read data only cannot be performed while a conversion, Auto Cal or Auto Zero are in progress.   |
| $\overline{\text{CS}}$               | Chip Select input pin. When a logic low is applied to this pin, the rising edge of SCLK shifts the data on DI into the address register. This low also brings DO out of TRI-STATE. With $\overline{\text{CS}}$ low the falling edge of SCLK shifts the data resulting from the previous ADC conversion out at the DO output, with the exception of the first bit of data. When $\overline{\text{CS}}$ is low continuously, the first bit of the data is clocked out on the rising edge of EOC (end of conversion). When $\overline{\text{CS}}$ is toggled the falling edge of $\overline{\text{CS}}$ always clocks out the first bit of data. $\overline{\text{CS}}$ should be brought low while SCLK is low. The falling edge of $\overline{\text{CS}}$ interrupts a conversion in progress and starts the sequence for a new conversion. When $\overline{\text{CS}}$ is brought back low during a conversion, that conversion is prematurely terminated. The data in the output latches may be corrupted. Therefore, when $\overline{\text{CS}}$ is brought low during a conversion in progress, the data output at that time should be ignored. $\overline{\text{CS}}$ may also be left continuously low. In this case it is imperative that the correct number of SCLK pulses be applied to the ADC in order to remain synchronous. After the ADC supply power is applied the device expects to see 13 clock pulses for each I/O sequence. The number of clock pulses the ADC expects is the same as the digital output word length. This word length can be modified by the data shifted in on the DO pin. <i>Table 5</i> details the data required. |
| $\overline{\text{DOR}}$              | Data Output Ready pin. This pin is an active push/pull output which is low when the conversion result is being shifted out and goes high to signal that all the data has been shifted out.  |
| SCLK                                 | Serial Data Clock input. The clock applied to this input controls the rate at which the serial data exchange occurs. The rising edge loads the information on the DI pin into the multiplexer address and mode select shift register. This address controls which channel of the analog input multiplexer (MUX) is selected and the mode of operation for the ADC. With $\overline{\text{CS}}$ low the falling edge of SCLK shifts the data resulting from the previous ADC conversion out on DO, with the exception of the first bit of data. When $\overline{\text{CS}}$ is low continuously, the first bit of the data is clocked out on the rising edge of EOC (end of conversion). When $\overline{\text{CS}}$ is toggled the falling edge of $\overline{\text{CS}}$ always clocks out the first bit of data. $\overline{\text{CS}}$ should be brought low when SCLK is low. The rise and fall times of the clock edges should not exceed 1 $\mu\text{s}$ .  |
| CCLK                                 | Conversion Clock input. The clock applied to this input controls the successive approximation conversion time interval and the acquisition time. The rise and fall times of the clock edges should not exceed 1 $\mu\text{s}$ .   |
| $V_{\text{REF}^+}$                   | Positive analog voltage reference input. In order to maintain accuracy, the voltage range of $V_{\text{REF}}$ ( $V_{\text{REF}} = V_{\text{REF}^+} + - V_{\text{REF}^-}$ ) is 1 $V_{\text{DC}}$ to 5.0 $V_{\text{DC}}$ and the voltage at $V_{\text{REF}^+}$ cannot exceed $V_{\text{A}^+}$ . See <i>Figure 5</i> for recommended bypassing.  |
| $V_{\text{REF}^-}$                   | The negative analog voltage reference input. In order to maintain accuracy, the voltage at this pin must not go below GND or exceed $V_{\text{A}^+}$ . (See <i>Figure 5</i> ).  |
| PD                                   | Power Down pin. When PD is high the ADC is powered down; when PD is low the ADC is powered up, or active. The ADC takes a maximum of 250 $\mu\text{s}$ to power up after the command is given.  |
| $V_{\text{A}^+}$<br>$V_{\text{D}^+}$ | These are the analog and digital power supply pins. $V_{\text{A}^+}$ and $V_{\text{D}^+}$ are not connected together on the chip. These pins should be tied to the same supply voltage and bypassed separately (see <i>Figure 5</i> ). The operating voltage range of $V_{\text{A}^+}$ and $V_{\text{D}^+}$ is 4.5 $V_{\text{DC}}$ to 5.5 $V_{\text{DC}}$ .   |
| DGND                                 | The digital ground pin (see <i>Figure 5</i> ).  |
| AGND                                 | The analog ground pin (see <i>Figure 5</i> ).   |

## Absolute Maximum Ratings

(Notes 1, 2)

**If Military/Aerospace specified devices are required, please contact the National Semiconductor Sales Office/Distributors for availability and specifications.**

|   |                           |
|---|---------------------------|
| Positive Supply Voltage<br>( $V^+ = V_{A^+} = V_{D^+}$ )    | 6.5V                      |
| Voltage at Inputs and Outputs<br>except CH0–CH7 and COM     | –0.3V to ( $V^+ + 0.3V$ ) |
| Voltage at Analog Inputs<br>CH0–CH7 and COM                 | GND –5V to ( $V^+ + 5V$ ) |
| $ V_{A^+} - V_{D^+} $                                       | 300 mV                    |
| Input Current at Any Pin (Note 3)                           | ±30 mA                    |
| Package Input Current (Note 3)                              | ±120 mA                   |
| Package Dissipation at<br>$T_A = 25^\circ\text{C}$ (Note 4) | 500 mW                    |
| ESD Susceptibility (Note 5)<br>Human Body Model             | 1500V                     |
| Soldering Information<br>N Packages (10 seconds)            | 260°C                     |
| SO Package (Note 6):<br>Vapor Phase (60 seconds)            | 215°C                     |
| Infrared (15 seconds)                                       | 220°C                     |
| Storage Temperature   | –65°C to +150°C           |

## Operating Ratings (Notes 1, 2)

|   |  |
|---|--|
| Operating Temperature Range   | $T_{\text{MIN}} \leq T_A \leq T_{\text{MAX}}$<br>–40°C $\leq T_A \leq$ +85°C |
| Supply Voltage ( $V^+ = V_{A^+} = V_{D^+}$ )  | +4.5V to +5.5V   |
| $ V_{A^+} - V_{D^+} $   | $\leq 100$ mV  |
| $V_{\text{REF}^+}$  | 0V to $V_{A^+}$  |
| $V_{\text{REF}^-}$  | 0V to ( $V_{\text{REF}^+} - 1V$ )  |
| $V_{\text{REF}}$ ( $V_{\text{REF}^+} - V_{\text{REF}^-}$ )                                      | 1V to $V_{A^+}$  |
| $V_{\text{REF}}$ Common Mode Voltage Range<br>[ $(V_{\text{REF}^+}) - (V_{\text{REF}^-})$ ] / 2 | 0.1 $V_{A^+}$ to 0.6 $V_{A^+}$   |
| A/DIN1, A/DIN2, MUXOUT1 and<br>MUXOUT2 Voltage Range  | 0V to $V_{A^+}$  |
| IN Common Mode Voltage Range<br>[ $(V_{\text{IN}^+}) - (V_{\text{IN}^-})$ ] / 2                 | 0V to $V_{A^+}$  |

## Package Thermal Resistance

| Part Number     | Thermal Resistance<br>( $\theta_{\text{JA}}$ ) |
|-----------------|--|
| ADC12(H)030CIWM | 70°C/W   |
| ADC12032CIWM    | 64°C/W   |
| ADC12034CIN     | 42°C/W   |
| ADC12034CIWM    | 57°C/W   |
| ADC12H034CIMSA  | 97°C/W   |
| ADC12(H)038CIWM | 50°C/W   |

**NOTE: Some of these devices may be obsolete or on Lifetime Buy status. Check our web site for product availability.**

## Converter Electrical Characteristics

The following specifications apply for  $V^+ = V_{A^+} = V_{D^+} = +5.0 V_{\text{DC}}$ ,  $V_{\text{REF}^+} = +4.096 V_{\text{DC}}$ ,  $V_{\text{REF}^-} = 0 V_{\text{DC}}$ , 12-bit + sign conversion mode,  $f_{\text{CK}} = f_{\text{SK}} = 8$  MHz for the ADC12H030, ADC12H032, ADC12H034 and ADC12H038,  $f_{\text{CK}} = f_{\text{SK}} = 5$  MHz for the ADC12030, ADC12032, ADC12034 and ADC12038,  $R_s = 25\Omega$ , source impedance for  $V_{\text{REF}^+}$  and  $V_{\text{REF}^-} \leq 25\Omega$ , fully-differential input with fixed 2.048V common-mode voltage, and  $10(t_{\text{CK}})$  acquisition time unless otherwise specified. **Boldface limits apply for  $T_A = T_J = T_{\text{MIN}}$  to  $T_{\text{MAX}}$** ; all other limits  $T_A = T_J = 25^\circ\text{C}$ . (Notes 7, 8, 9)

| Symbol                                  | Parameter                        | Conditions   | Typical<br>(Note 10) | Limits<br>(Note 11) | Units<br>(Limits) |
|---|----------------------------------|--|----------------------|---------------------|-------------------|
| <b>STATIC CONVERTER CHARACTERISTICS</b> |                                  |  |                      |                     |                   |
|   | Resolution with No Missing Codes |  |                      | <b>12 + sign</b>    | Bits (min)        |
| ILE                                     | Integral Linearity Error         | After Auto Cal (Notes 12, 18)  | ±1/2                 | <b>±1</b>           | LSB (max)         |
| DNL                                     | Differential Non-Linearity       | After Auto Cal   |                      | <b>±1</b>           | LSB (max)         |
|   | Positive Full-Scale Error        | After Auto Cal (Notes 12, 18)  | ±1/2                 | <b>±3.0</b>         | LSB (max)         |
|   | Negative Full-Scale Error        | After Auto Cal (Notes 12, 18)  | ±1/2                 | <b>±3.0</b>         | LSB (max)         |
|   | Offset Error                     | After Auto Cal (Notes 5, 18)<br>$V_{\text{IN}(+)} = V_{\text{IN}(-)} = 2.048V$ | ±1/2                 | <b>±2</b>           | LSB (max)         |
|   | DC Common Mode Error             | After Auto Cal (Note 15)   | ±2                   | <b>±3.5</b>         | LSB (max)         |
| TUE                                     | Total Unadjusted Error           | After Auto Cal (Notes 12, 13, 14)  | ±1                   |                     | LSB               |
|   | Resolution with No Missing Codes | 8-bit + sign mode  |                      | <b>8 + sign</b>     | Bits (min)        |
| INL                                     | Integral Linearity Error         | 8-bit + sign mode (Note 12)  |                      | <b>±1/2</b>         | LSB (max)         |
| DNL                                     | Differential Non-Linearity       | 8-bit + sign mode  |                      | <b>±3/4</b>         | LSB (max)         |
|   | Positive Full-Scale Error        | 8-bit + sign mode (Note 12)  |                      | <b>±1/2</b>         | LSB (max)         |
|   | Negative Full-Scale Error        | 8-bit + sign mode (Note 12)  |                      | <b>±1/2</b>         | LSB (max)         |

| Symbol  | Parameter  | Conditions   | Typical<br>(Note 10) | Limits<br>(Note 11)                                       | Units<br>(Limits)      |
|---|--|--|----------------------|---|------------------------|
|   | Offset Error                                       | 8-bit + sign mode, after Auto Zero<br>$V_{IN(+)} = V_{IN(-)} = + 2.048V$ (Note 13) |                      | $\pm 1/2$   | LSB (max)              |
| TUE   | Total Unadjusted Error                             | 8-bit + sign mode after Auto Zero<br>(Notes 12, 13, 14)                            |                      | $\pm 3/4$   | LSB (max)              |
|   | Multiplexer Chan-to-Chan Matching                  |  | $\pm 0.05$           |   | LSB                    |
|   | Power Supply Sensitivity                           | $V^+ = +5V \pm 10\%$ , $V_{REF} = +4.096V$   |                      |   |                        |
|   | Offset Error                                       |  | $\pm 0.5$            | $\pm 1$   | LSB (max)              |
|   | + Full-Scale Error                                 |  | $\pm 0.5$            | $\pm 1.5$   | LSB (max)              |
|   | - Full-Scale Error                                 |  | $\pm 0.5$            | $\pm 1.5$   | LSB (max)              |
|   | Integral Linearity Error                           |  | $\pm 0.5$            |   | LSB                    |
|   | Output Data from "12-Bit Conversion of Offset"     | (see Table 5) (Note 20)  |                      | <b>+10</b><br><b>-10</b>                                  | LSB (max)<br>LSB (min) |
|   | Output Data from "12-Bit Conversion of Full-Scale" | (see Table 5) (Note 20)  |                      | <b>4095</b><br><b>4093</b>                                | LSB (max)<br>LSB (min) |
| <b>UNIPOlar DYNAMIC CONVERTER CHARACTERISTICS</b>                     |  |  |                      |   |                        |
| S/(N+D)   | Signal-to-Noise Plus Distortion Ratio              | $f_{IN} = 1$ kHz, $V_{IN} = 5 V_{P-P}$ , $V_{REF^+} = 5.0V$                        | 69.4                 |   | dB                     |
|   |  | $f_{IN} = 20$ kHz, $V_{IN} = 5 V_{P-P}$ , $V_{REF^+} = 5.0V$                       | 68.3                 |   | dB                     |
|   |  | $f_{IN} = 40$ kHz, $V_{IN} = 5 V_{P-P}$ , $V_{REF^+} = 5.0V$                       | 65.7                 |   | dB                     |
|   | -3 dB Full Power Bandwidth                         | $V_{IN} = 5 V_{P-P}$ , where S/(N+D) drops 3 dB                                    | 31                   |   | kHz                    |
| <b>DIFFERENTIAL DYNAMIC CONVERTER CHARACTERISTICS</b>                 |  |  |                      |   |                        |
| S/(N+D)   | Signal-to-Noise Plus Distortion Ratio              | $f_{IN} = 1$ kHz, $V_{IN} = \pm 5V$ , $V_{REF^+} = 5.0V$                           | 77.0                 |   | dB                     |
|   |  | $f_{IN} = 20$ kHz, $V_{IN} = \pm 5V$ , $V_{REF^+} = 5.0V$                          | 73.9                 |   | dB                     |
|   |  | $f_{IN} = 40$ kHz, $V_{IN} = \pm 5V$ , $V_{REF^+} = 5.0V$                          | 67.0                 |   | dB                     |
|   | -3 dB Full Power Bandwidth                         | $V_{IN} = \pm 5V$ , where S/(N+D) drops 3 dB                                       | 40                   |   | kHz                    |
| <b>REFERENCE INPUT, ANALOG INPUTS AND MULTIPLEXER CHARACTERISTICS</b> |  |  |                      |   |                        |
| $C_{REF}$   | Reference Input Capacitance                        |  | 85                   |   | pF                     |
| $C_{AD}$  | A/DIN1, A/DIN2 Analog Input Capacitance            |  | 75                   |   | pF                     |
|   | A/DIN1, A/DIN2 Analog Input Leakage Current        | $V_{IN} = +5.0V$ or $V_{IN} = 0V$  | $\pm 0.1$            | $\pm 1.0$   | $\mu A$ (max)          |
|   | CH0-CH7 and COM Input Voltage                      |  |                      | <b>GND - 0.05</b><br><b>(<math>V_{A^+}</math>) + 0.05</b> | V (min)<br>V (max)     |
| $C_{CH}$  | CH0-CH7 and COM Input Capacitance                  |  | 10                   |   | pF                     |
| $C_{MUXOUT}$  | MUX Output Capacitance                             |  | 20                   |   | pF                     |
|   | Off Channel Leakage CH0-CH7 and COM Pins (Note 16) | On Channel = 5V and Off Channel = 0V   | -0.01                | <b>-0.3</b>   | $\mu A$ (min)          |
|   |  | On Channel = 0V and Off Channel = 5V   | 0.01                 | <b>0.3</b>  | $\mu A$ (max)          |
|   | On Channel Leakage CH0-CH7 and COM Pins (Note 16)  | On Channel = 5V and Off Channel = 0V   | 0.01                 | <b>0.3</b>  | $\mu A$ (max)          |
|   |  | On Channel = 0V and Off Channel = 5V   | -0.01                | <b>-0.3</b>   | $\mu A$ (min)          |
|   | MUXOUT1 and MUXOUT2 Leakage Current                | $V_{MUXOUT} = 5.0V$ or $V_{MUXOUT} = 0V$   | 0.01                 | <b>0.3</b>  | $\mu A$ (max)          |
| $R_{ON}$  | MUX On Resistance                                  | $V_{IN} = 2.5V$ and $V_{MUXOUT} = 2.4V$  | 850                  | <b>1150</b>   | $\Omega$ (max)         |
|   | $R_{ON}$ Matching Chan-to-Chan                     | $V_{IN} = 2.5V$ and $V_{MUXOUT} = 2.4V$  | 5                    |   | %                      |
|   | Chan-to-Chan Crosstalk                             | $V_{IN} = 5 V_{P-P}$ , $f_{IN} = 40$ kHz   | -72                  |   | dB                     |
|   | MUX Bandwidth                                      |  | 90                   |   | kHz                    |

## DC and Logic Electrical Characteristics

The following specifications apply for  $V^+ = V_{A^+} = V_{D^+} = +5.0 V_{DC}$ ,  $V_{REF^+} = +4.096 V_{DC}$ ,  $V_{REF^-} = 0 V_{DC}$ , 12-bit + sign conversion mode,  $f_{CK} = f_{SK} = 8 \text{ MHz}$  for the ADC12H030, ADC12H032, ADC12H034 and ADC12H038,  $f_{CK} = f_{SK} = 5 \text{ MHz}$  for the ADC12030, ADC12032, ADC12034 and ADC12038,  $R_S = 25\Omega$ , source impedance for  $V_{REF^+}$  and  $V_{REF^-} \leq 25\Omega$ , fully-differential input with fixed 2.048V common-mode voltage, and  $10(t_{CK})$  acquisition time unless otherwise specified. **Boldface limits apply for  $T_A = T_J = T_{MIN}$  to  $T_{MAX}$** ; all other limits  $T_A = T_J = 25^\circ\text{C}$ . (Notes 7, 8, 9)

| Symbol  | Parameter  | Conditions  | Typical<br>(Note 10) | Limits<br>(Note 11) | Units<br>(Limits)   |
|---|--|---|----------------------|---------------------|---------------------|
| <b>CCLK, <math>\overline{\text{CS}}</math>, CONV, DI, PD AND SCLK INPUT CHARACTERISTICS</b> |  |   |                      |                     |                     |
| $V_{IN(1)}$   | Logical "1" Input Voltage  | $V^+ = 5.5V$  |                      | <b>2.0</b>          | V (min)             |
| $V_{IN(0)}$   | Logical "0" Input Voltage  | $V^+ = 4.5V$  |                      | <b>0.8</b>          | V (max)             |
| $I_{IN(1)}$   | Logical "1" Input Current  | $V_{IN} = 5.0V$   | 0.005                | <b>1.0</b>          | $\mu\text{A}$ (max) |
| $I_{IN(0)}$   | Logical "0" Input Current  | $V_{IN} = 0V$   | -0.005               | <b>-1.0</b>         | $\mu\text{A}$ (min) |
| <b>DO, EOC AND DOR DIGITAL OUTPUT CHARACTERISTICS</b>                                       |  |   |                      |                     |                     |
| $V_{OUT(1)}$  | Logical "1" Output Voltage   | $V^+ = 4.5V, I_{OUT} = -360 \mu\text{A}$                      |                      | <b>2.4</b>          | V (min)             |
|   |  | $V^+ = 4.5V, I_{OUT} = -10 \mu\text{A}$                       |                      | <b>4.25</b>         | V (min)             |
| $V_{OUT(0)}$  | Logical "0" Output Voltage   | $V^+ = 4.5V, I_{OUT} = 1.6 \text{ mA}$                        |                      | <b>0.4</b>          | V (max)             |
| $I_{OUT}$   | TRI-STATE Output Current   | $V_{OUT} = 0V$  | -0.1                 | <b>-3.0</b>         | $\mu\text{A}$ (max) |
|   |  | $V_{OUT} = 5V$  | 0.1                  | <b>3.0</b>          | $\mu\text{A}$ (max) |
| $+I_{SC}$   | Output Short Circuit Source Current                                    | $V_{OUT} = 0V$  | 14                   | <b>6.5</b>          | mA (min)            |
| $-I_{SC}$   | Output Short Circuit Sink Current                                      | $V_{OUT} = V_{D^+}$   | 16                   | <b>8.0</b>          | mA (min)            |
| <b>POWER SUPPLY CHARACTERISTICS</b>   |  |   |                      |                     |                     |
| $I_{D^+}$   | Digital Supply Current<br>ADC12030, ADC12032, ADC12034 and<br>ADC12038 | Awake   | 1.6                  | <b>2.5</b>          | mA (max)            |
|   |  | $\overline{\text{CS}} = \text{HIGH}$ , Powered Down, CCLK on  | 600                  |                     | $\mu\text{A}$       |
|   |  | $\overline{\text{CS}} = \text{HIGH}$ , Powered Down, CCLK off | 20                   |                     | $\mu\text{A}$       |
| $I_{A^+}$   | Positive Analog Supply Current   | Awake   | 2.7                  | <b>4.0</b>          | mA (max)            |
|   |  | $\overline{\text{CS}} = \text{HIGH}$ , Powered Down, CCLK on  | 10                   |                     | $\mu\text{A}$       |
|   |  | $\overline{\text{CS}} = \text{HIGH}$ , Powered Down, CCLK off | 0.1                  |                     | $\mu\text{A}$       |
| $I_{REF}$   | Reference Input Current  | Awake   | 70                   |                     | $\mu\text{A}$       |
|   |  | $\overline{\text{CS}} = \text{HIGH}$ , Powered Down           | 0.1                  |                     | $\mu\text{A}$       |

## AC Electrical Characteristics

The following specifications apply for  $V^+ = V_{A^+} = V_{D^+} = +5.0 V_{DC}$ ;  $V_{REF^+} = +4.096 V_{DC}$ ;  $V_{REF^-} = 0 V_{DC}$ ; 12-bit + sign conversion mode,  $t_r = t_f = 3 \text{ ns}$ ,  $f_{CK} = f_{SK} = 8 \text{ MHz}$  for the ADC12H030, ADC12H032, ADC12H034 and ADC12H038,  $f_{CK} = f_{SK} = 5 \text{ MHz}$  for the ADC12030, ADC12032, ADC12034 and ADC12038,  $R_S = 25\Omega$ , source impedance for  $V_{REF^+}$  and  $V_{REF^-} \leq 25\Omega$ , fully-differential input with fixed 2.048V common-mode voltage, and  $10(t_{CK})$  acquisition time unless otherwise specified. **Boldface limits apply for  $T_A = T_J = T_{MIN}$  to  $T_{MAX}$** ; all other limits  $T_A = T_J = 25^\circ\text{C}$ . (Note 17)

| Symbol                | Parameter   | Conditions                 | Typical<br>(Note 10)   | ADC12H030/2/4/8<br>Limits<br>(Note 11)                           | ADC12030/2/4/8<br>Limits<br>(Note 11)                            | Units<br>(Limits)  |  |  |
|-----------------------|---|----------------------------|--|--|--|--|--|--|
| $f_{CK}$              | Conversion Clock (CCLK)<br>Frequency  |                            | 10   | <b>8</b>   | <b>5</b>   | MHz (max)  |  |  |
|                       |   |                            | 1  |  |  | MHz (min)  |  |  |
| $f_{SK}$              | Serial Data Clock SCLK Frequency  |                            | 10   | <b>8</b>   | <b>5</b>   | MHz (max)  |  |  |
|                       |   |                            | 0  |  |  | Hz (min)   |  |  |
|                       | Conversion Clock Duty Cycle   |                            |  | <b>40</b>  | <b>40</b>  | % (min)  |  |  |
|                       |   |                            |  | <b>60</b>  | <b>60</b>  | % (max)  |  |  |
|                       | Serial Data Clock Duty Cycle  |                            |  | <b>40</b>  | <b>40</b>  | % (min)  |  |  |
|                       |   |                            |  | <b>60</b>  | <b>60</b>  | % (max)  |  |  |
| $t_C$                 | Conversion Time   | 12-Bit + Sign or<br>12-Bit | $44(t_{CK})$   | <b><math>44(t_{CK})</math></b><br><b>5.5</b>                     | <b><math>44(t_{CK})</math></b><br><b>8.8</b>                     | (max)<br>$\mu\text{s}$ (max)                                   |  |  |
|                       |   | 8-Bit + Sign or 8-<br>Bit  | $21(t_{CK})$   | <b><math>21(t_{CK})</math></b><br><b>2.625</b>                   | <b><math>21(t_{CK})</math></b><br><b>4.2</b>                     | (max)<br>$\mu\text{s}$ (max)                                   |  |  |
| $t_A$                 | Acquisition Time (Note 19)  | 6 Cycles<br>Programmed     | $6(t_{CK})$  | <b><math>6(t_{CK})</math></b><br><b><math>7(t_{CK})</math></b>   | <b><math>6(t_{CK})</math></b><br><b><math>7(t_{CK})</math></b>   | (min)<br>(max)   |  |  |
|                       |   |                            |  |  | <b>0.75</b><br><b>0.875</b>                                      | <b>1.2</b><br><b>1.4</b>                                       | $\mu\text{s}$ (min)<br>$\mu\text{s}$ (max)                     |  |
|                       |   | 10 Cycles<br>Programmed    | $10(t_{CK})$   | <b><math>10(t_{CK})</math></b><br><b><math>11(t_{CK})</math></b> | <b><math>10(t_{CK})</math></b><br><b><math>11(t_{CK})</math></b> | (min)<br>(max)   |  |  |
|                       |   |                            |  | <b>1.25</b><br><b>1.375</b>                                      | <b>2.0</b><br><b>2.2</b>   | $\mu\text{s}$ (min)<br>$\mu\text{s}$ (max)                     |  |  |
|                       |   | 18 Cycles<br>Programmed    | $18(t_{CK})$   | <b><math>18(t_{CK})</math></b><br><b><math>19(t_{CK})</math></b> | <b><math>18(t_{CK})</math></b><br><b><math>19(t_{CK})</math></b> | (min)<br>(max)   |  |  |
|                       |   |                            |  | <b>2.25</b><br><b>2.375</b>                                      | <b>3.6</b><br><b>3.8</b>   | $\mu\text{s}$ (min)<br>$\mu\text{s}$ (max)                     |  |  |
|                       |   | 34 Cycles<br>Programmed    | $34(t_{CK})$   | <b><math>34(t_{CK})</math></b><br><b><math>35(t_{CK})</math></b> | <b><math>34(t_{CK})</math></b><br><b><math>35(t_{CK})</math></b> | (min)<br>(max)   |  |  |
|                       |   |                            |  | <b>4.25</b><br><b>4.375</b>                                      | <b>6.8</b><br><b>7.0</b>   | $\mu\text{s}$ (min)<br>$\mu\text{s}$ (max)                     |  |  |
|                       |   | $t_{CKAL}$                 | Self-Calibration Time  |  | $4944(t_{CK})$   | <b><math>4944(t_{CK})</math></b><br><b>618.0</b>               | <b><math>4944(t_{CK})</math></b><br><b>988.8</b>               | (max)<br>$\mu\text{s}$ (max)               |
|                       |   | $t_{AZ}$                   | Auto Zero Time   |  | $76(t_{CK})$   | <b><math>76(t_{CK})</math></b><br><b>9.5</b>                   | <b><math>76(t_{CK})</math></b><br><b>15.2</b>                  | (max)<br>$\mu\text{s}$ (max)               |
|                       |   | $t_{SYNC}$                 | Self-Calibration or Auto Zero<br>Synchronization Time from DOR |  | $2(t_{CK})$  | <b><math>2(t_{CK})</math></b><br><b><math>3(t_{CK})</math></b> | <b><math>2(t_{CK})</math></b><br><b><math>3(t_{CK})</math></b> | (min)<br>(max)                             |
|                       |   |                            |  |  |  | <b>0.250</b><br><b>0.375</b>                                   | <b>0.40</b><br><b>0.60</b>                                     | $\mu\text{s}$ (min)<br>$\mu\text{s}$ (max) |
| $t_{\overline{DOR}}$  | DOR High Time when $\overline{CS}$ is Low<br>Continuously for Read Data and<br>Software Power Up/Down |                            | $9(t_{SK})$  | <b><math>9(t_{SK})</math></b><br><b>1.125</b>                    | <b><math>9(t_{SK})</math></b><br><b>1.8</b>                      | (max)<br>$\mu\text{s}$ (max)                                   |  |  |
| $t_{\overline{CONV}}$ | $\overline{CONV}$ Valid Data Time   |                            | $8(t_{SK})$  | <b><math>8(t_{SK})</math></b>                                    | <b><math>8(t_{SK})</math></b>                                    | (max)  |  |  |
|                       |   |                            |  | <b>1.0</b>   | <b>1.6</b>   | $\mu\text{s}$ (max)  |  |  |

## Timing Characteristics

The following specifications apply for  $V^+ = V_{A^+} = V_{D^+} = +5.0 V_{DC}$ ,  $V_{REF^+} = +4.096 V_{DC}$ ,  $V_{REF^-} = 0 V_{DC}$ , 12-bit + sign conversion mode,  $t_r = t_f = 3 \text{ ns}$ ,  $f_{CK} = f_{SK} = 8 \text{ MHz}$  for the ADC12H030, ADC12H032, ADC12H034 and ADC12H03,  $f_{CK} = f_{SK} = 5 \text{ MHz}$  for the ADC12030, ADC12032, ADC12034 and ADC12038,  $R_S = 25 \Omega$ , source impedance for  $V_{REF^+}$  and  $V_{REF^-} \leq 25 \Omega$ , fully-differential input with fixed 2.048V common-mode voltage, and  $10(t_{CK})$  acquisition time unless otherwise specified. **Boldface limits apply for  $T_A = T_J = T_{MIN}$  to  $T_{MAX}$** ; all other limits  $T_A = T_J = 25^\circ\text{C}$ . (Note 17)

| Symbol           | Parameter   | Conditions                              | Typical<br>(Note 10) | Limits<br>(Note 11)   | Units<br>(Limits)    |
|------------------|---|---|----------------------|-----------------------|----------------------|
| $t_{HPU}$        | Hardware Power-Up Time, Time from PD Falling Edge to EOC Rising Edge                |   | 140                  | <b>250</b>            | $\mu\text{s}$ (max)  |
| $t_{SPU}$        | Software Power-Up Time, Time from Serial Data Clock Falling Edge to EOC Rising Edge |   | 140                  | <b>250</b>            | $\mu\text{s}$ (max)  |
| $t_{ACC}$        | Access Time Delay from $\overline{CS}$ Falling Edge to DO Data Valid                |   | 20                   | <b>50</b>             | ns (max)             |
| $t_{SET-UP}$     | Set-Up Time of $\overline{CS}$ Falling Edge to Serial Data Clock Rising Edge        |   |                      | <b>30</b>             | ns (min)             |
| $t_{DELAY}$      | Delay from SCLK Falling Edge to $\overline{CS}$ Falling Edge                        |   | 0                    | <b>5</b>              | ns (min)             |
| $t_{1H}, t_{0H}$ | Delay from $\overline{CS}$ Rising Edge to DO TRI-STATE                              | $R_L = 3\text{k}, C_L = 100 \text{ pF}$ | 40                   | <b>100</b>            | ns (max)             |
| $t_{HDI}$        | DI Hold Time from Serial Data Clock Rising Edge                                     |   | 5                    | <b>15</b>             | ns (min)             |
| $t_{SDI}$        | DI Set-Up Time from Serial Data Clock Rising Edge                                   |   | 5                    | <b>10</b>             | ns (min)             |
| $t_{HDO}$        | DO Hold Time from Serial Data Clock Falling Edge                                    | $R_L = 3\text{k}, C_L = 100 \text{ pF}$ | 25                   | <b>50</b><br><b>5</b> | ns (max)<br>ns (min) |
| $t_{DDO}$        | Delay from Serial Data Clock Falling Edge to DO Data Valid                          |   | 35                   | <b>50</b>             | ns (max)             |
| $t_{RDO}$        | DO Rise Time, TRI-STATE to High   | $R_L = 3\text{k}, C_L = 100 \text{ pF}$ | 10                   | <b>30</b>             | ns (max)             |
|                  | DO Rise Time, Low to High   | $R_L = 3\text{k}, C_L = 100 \text{ pF}$ | 10                   | <b>30</b>             | ns (max)             |
| $t_{FDO}$        | DO Fall Time, TRI-STATE to Low  | $R_L = 3\text{k}, C_L = 100 \text{ pF}$ | 12                   | <b>30</b>             | ns (max)             |
|                  | DO Fall Time, High to Low   | $R_L = 3\text{k}, C_L = 100 \text{ pF}$ | 12                   | <b>30</b>             | ns (max)             |
| $t_{CD}$         | Delay from $\overline{CS}$ Falling Edge to $\overline{DOR}$ Falling Edge            |   | 25                   | <b>45</b>             | ns (max)             |
| $t_{SD}$         | Delay from Serial Data Clock Falling Edge to $\overline{DOR}$ Rising Edge           |   | 25                   | <b>45</b>             | ns (max)             |
| $C_{IN}$         | Capacitance of Logic Inputs   |   | 10                   |                       | pF                   |
| $C_{OUT}$        | Capacitance of Logic Outputs  |   | 20                   |                       | pF                   |

**Note 1:** Absolute Maximum Ratings indicate limits beyond which damage to the device may occur. Operating Ratings indicate conditions for which the device is functional, but do not guarantee specific performance limits. For guaranteed specifications and test conditions, see the Electrical Characteristics. The guaranteed specifications apply only for the test conditions listed. Some performance characteristics may degrade when the device is not operated under the listed test conditions.

**Note 2:** All voltages are measured with respect to GND, unless otherwise specified.

**Note 3:** When the input voltage ( $V_{IN}$ ) at any pin exceeds the power supplies ( $V_{IN} < \text{GND}$  or  $V_{IN} > V_{A^+}$  or  $V_{D^+}$ ), the current at that pin should be limited to 30 mA. The 120 mA maximum package input current rating limits the number of pins that can safely exceed the power supplies with an input current of 30 mA to four.

**Note 4:** The maximum power dissipation must be derated at elevated temperatures and is dictated by  $T_{Jmax}$ ,  $\theta_{JA}$  and the ambient temperature,  $T_A$ . The maximum allowable power dissipation at any temperature is  $P_D = (T_{Jmax} - T_A)/\theta_{JA}$  or the number given in the Absolute Maximum Ratings, whichever is lower.

**Note 5:** The human body model is a 100 pF capacitor discharged through a 1.5 k $\Omega$  resistor into each pin.

**Note 6:** See AN450 "Surface Mounting Methods and Their Effect on Product Reliability" or the section titled "Surface Mount" found in any post 1986 National Semiconductor Linear Data Book for other methods of soldering surface mount devices.

**Note 7:** Two on-chip diodes are tied to each analog input through a series resistor as shown below. Input voltage magnitude up to 5V above  $V_{A^+}$  or 5V below GND will not damage this device. However, errors in the conversion can occur (if these diodes are forward biased by more than 50 mV) if the input voltage magnitude of selected or unselected analog input go above  $V_{A^+}$  or below GND by more than 50 mV. As an example, if  $V_{A^+}$  is 4.5  $V_{DC}$ , full-scale input voltage must be  $\leq 4.55 V_{DC}$  to ensure accurate conversions.

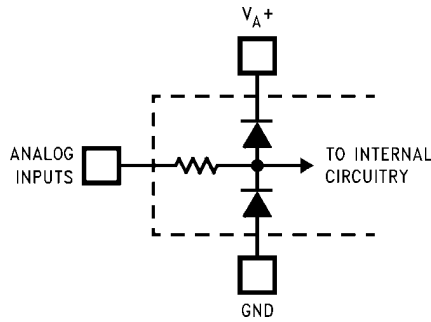

1135402

- Note 8:** To guarantee accuracy, it is required that the  $V_{A+}$  and  $V_{D+}$  be connected together to the same power supply with separate bypass capacitors at each  $V+$  pin.
- Note 9:** With the test condition for  $V_{REF}$  ( $V_{REF+} - V_{REF-}$ ) given as +4.096V, the 12-bit LSB is 1.0 mV and the 8-bit LSB is 16.0 mV.
- Note 10:** Typical figures are at  $T_J = T_A = 25^\circ\text{C}$  and represent most likely parametric norm.
- Note 11:** Tested limits are guaranteed to National's AOQL (Average Outgoing Quality Level).
- Note 12:** Positive integral linearity Error is defined as the deviation of the analog value, expressed in LSBs, from the straight line that passes through positive full-scale and zero. For Negative Integral Linearity Error, the straight line passes through negative full-scale and zero (see *Figures 2, 3*).
- Note 13:** Offset error is a measure of the deviation from the mid-scale voltage (a code of zero), expressed in LSB. It is the worst-case value of the code transitions between 1 to 0 and 0 to +1 (see *Figure 4*).
- Note 14:** Total unadjusted error includes offset, full-scale, linearity and multiplexer errors.
- Note 15:** The DC common-mode error is measured in the differential multiplexer mode with the assigned positive and negative input channels shorted together.
- Note 16:** Channel leakage current is measured after the channel selection.
- Note 17:** Timing specifications are tested at the TTL logic levels,  $V_{IL} = 0.4\text{V}$  for a falling edge and  $V_{IH} = 2.4\text{V}$  for a rising edge. TRI-STATE output voltage is forced to 1.4V.
- Note 18:** The ADC12030 family's self-calibration technique ensures linearity and offset errors as specified, but noise inherent in the self-calibration process will result in a maximum repeatability uncertainty of 0.2 LSB.
- Note 19:** If SCLK and CCLK are driven from the same clock source, then  $t_a$  is 6, 10, 18 or 34 clock periods minimum and maximum.
- Note 20:** The "12-Bit Conversion of Offset" and "12-Bit Conversion of Full-Scale" modes are intended to test the functionality of the device. Therefore, the output data from these modes are not an indication of the accuracy of a conversion result.

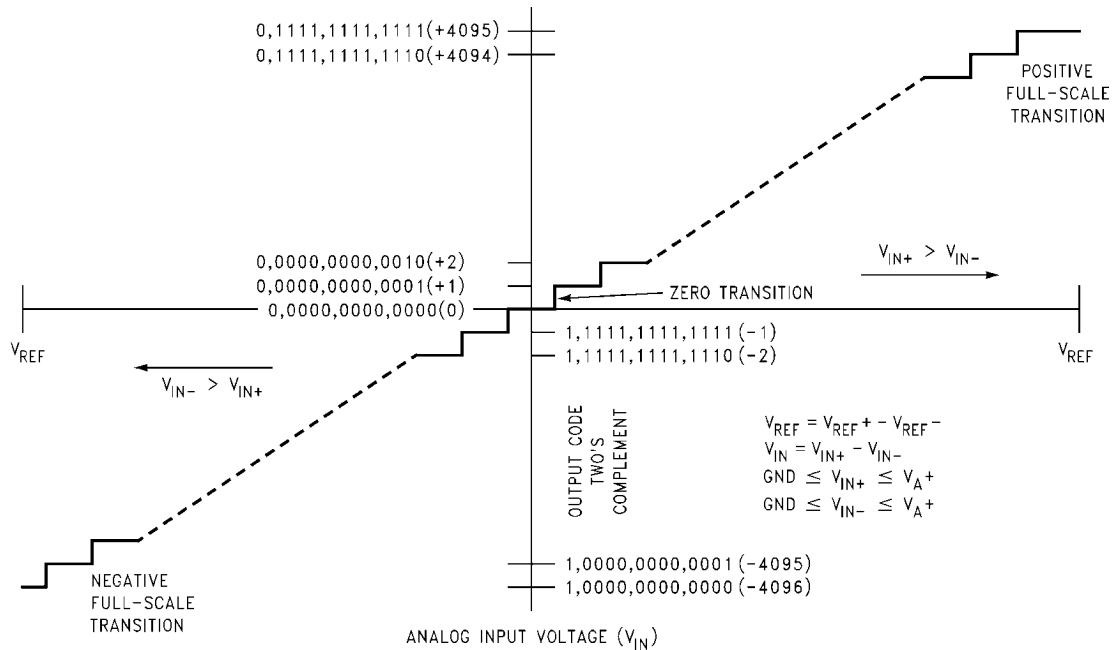

1135410

**FIGURE 1. Transfer Characteristic**

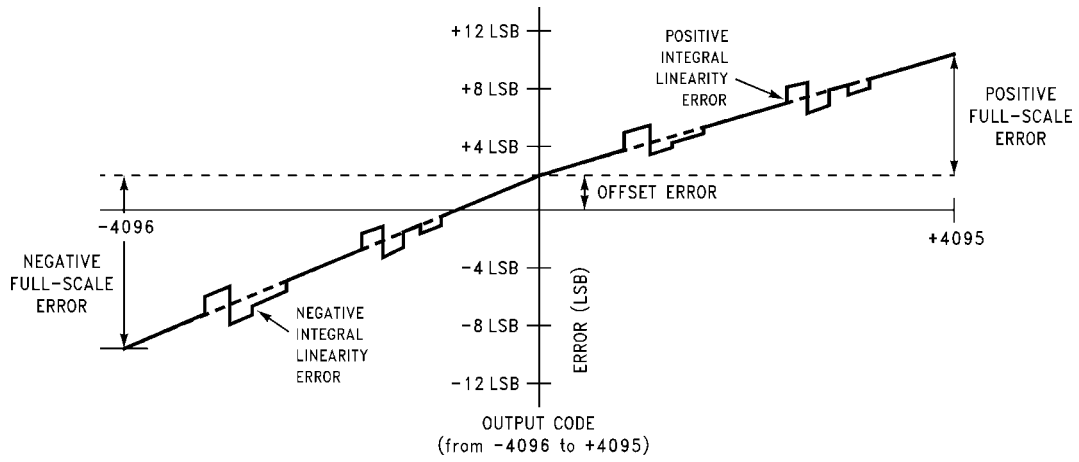

1135411

FIGURE 2. Simplified Error Curve vs. Output Code without Auto Calibration or Auto Zero Cycles

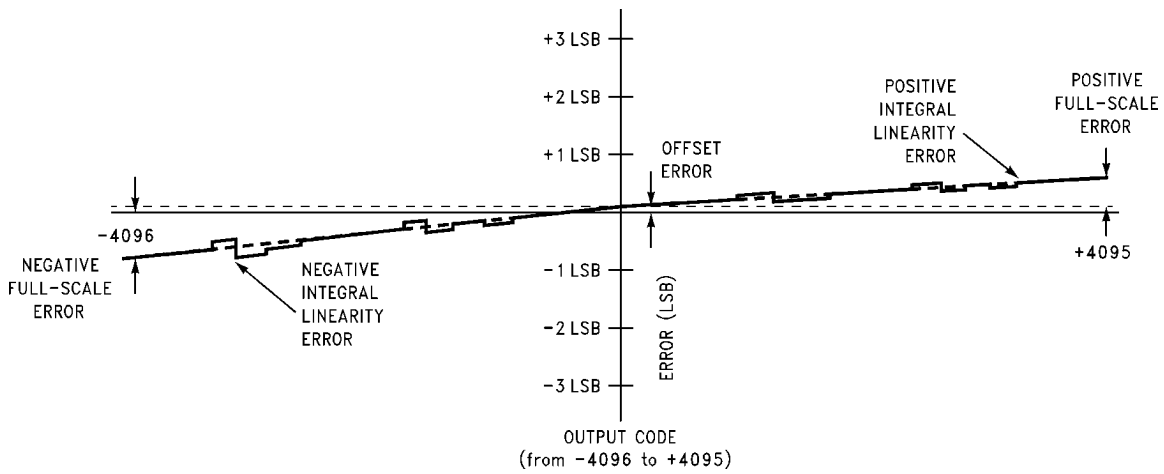

1135412

FIGURE 3. Simplified Error Curve vs. Output Code after Auto Calibration Cycle

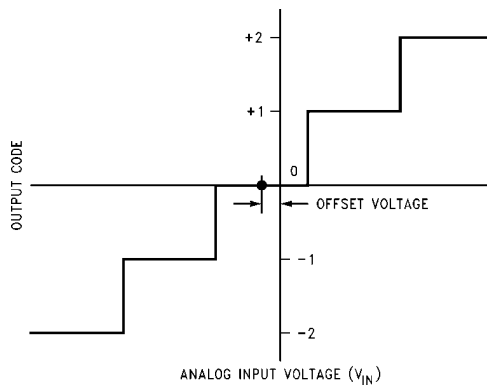

1135413

FIGURE 4. Offset or Zero Error Voltage

**Typical Performance Characteristics** The following curves apply for 12-bit + sign mode after Auto Calibration unless otherwise specified. The performance for 8-bit + sign mode is equal to or better than shown. (Note 9)

**Linearity Error Change vs. Clock Frequency**

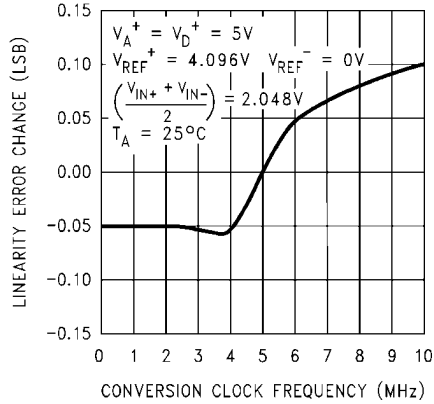

1135453

**Linearity Error Change vs. Temperature**

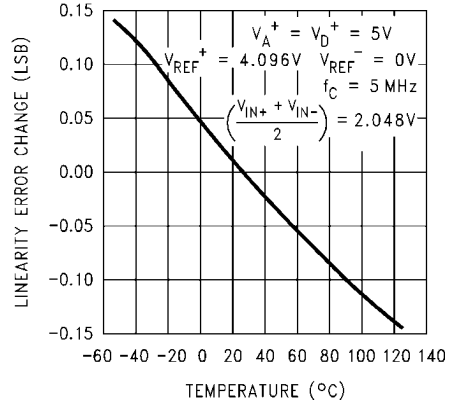

1135454

**Linearity Error Change vs. Reference Voltage**

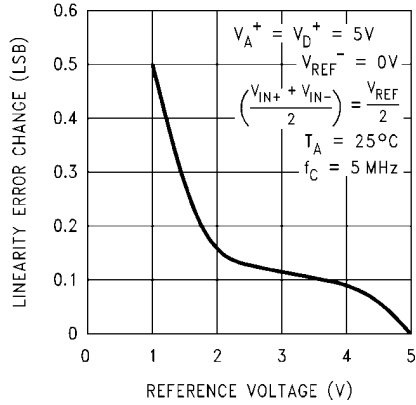

1135455

**Linearity Error Change vs. Supply Voltage**

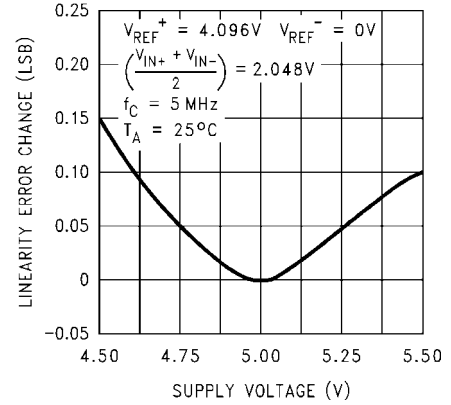

1135456

**Full-Scale Error Change vs. Clock Frequency**

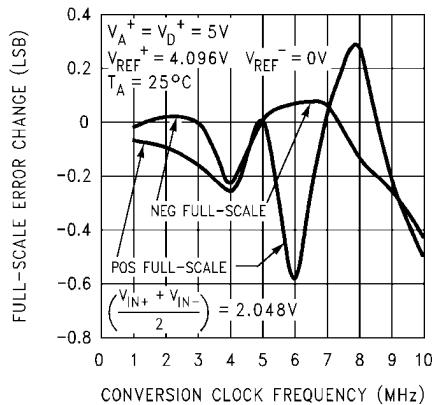

1135457

**Full-Scale Error Change vs. Temperature**

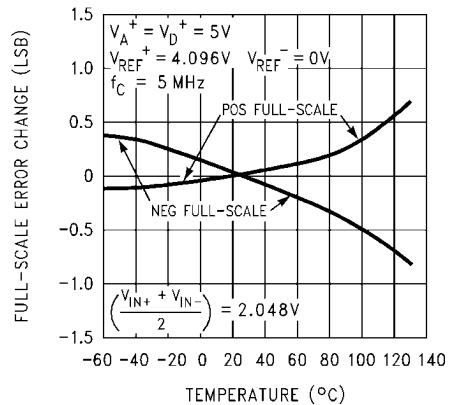

1135458

**Full-Scale Error Change vs. Reference Voltage**

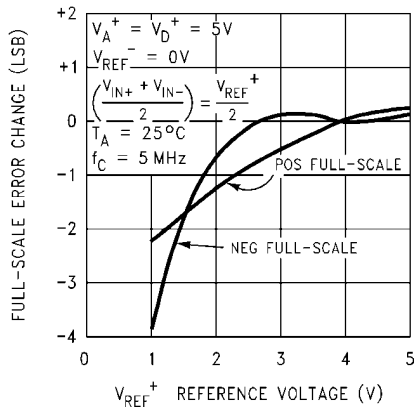

1135459

**Full-Scale Error Change vs. Supply Voltage**

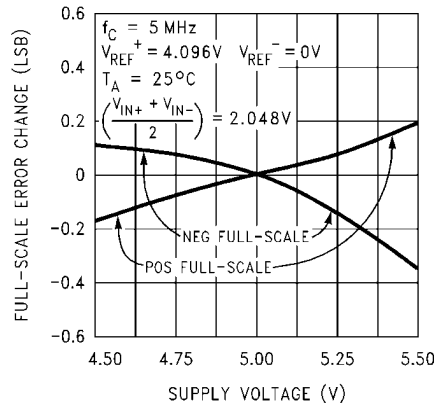

1135460

**Offset or Zero Error Change vs. Clock Frequency**

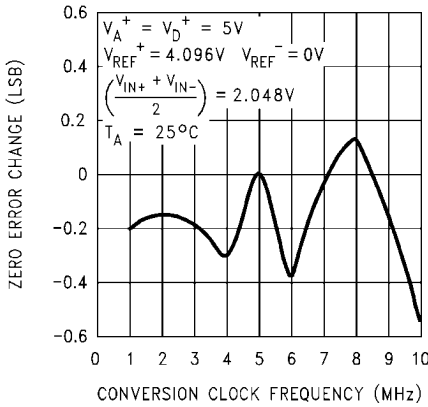

1135461

**Offset or Zero Error Change vs. Temperature**

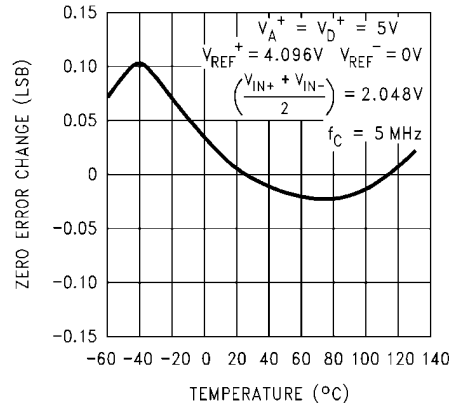

1135462

**Offset or Zero Error Change vs. Reference Voltage**

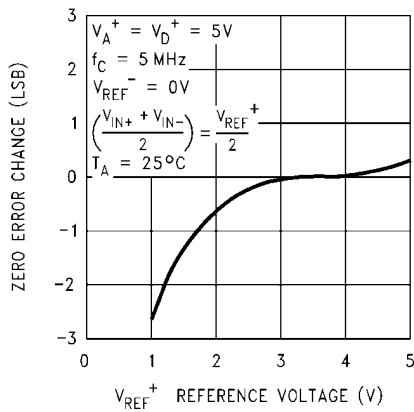

1135463

**Offset or Zero Error Change vs. Supply Voltage**

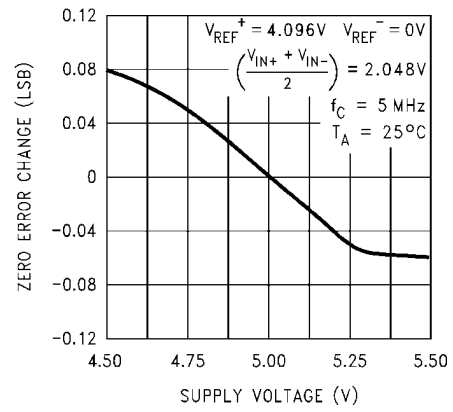

1135464

**Analog Supply Current vs. Temperature**

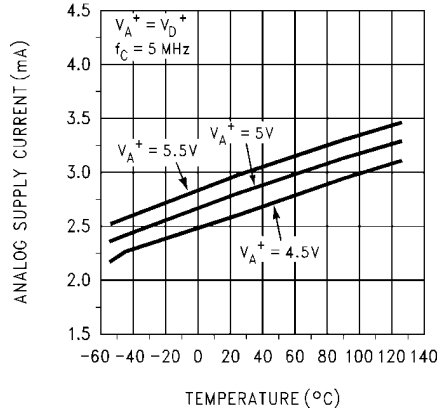

1135465

**Digital Supply Current vs. Clock Frequency**

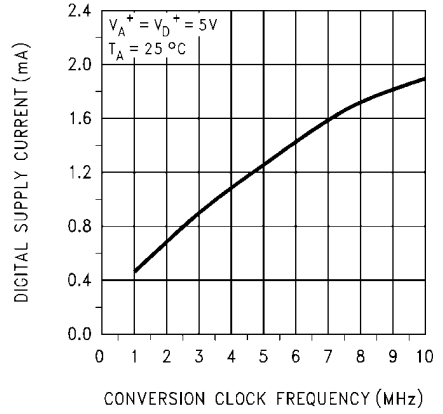

1135466

**Digital Supply Current vs. Temperature**

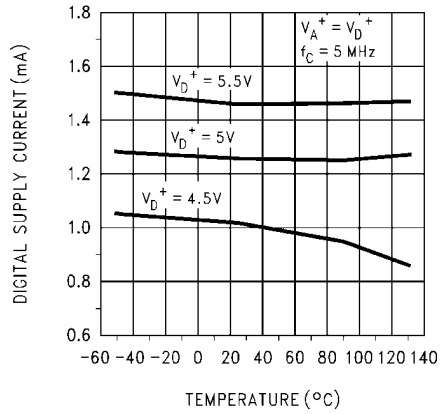

1135467

# Typical Dynamic Performance Characteristics

after Auto Calibration unless otherwise specified.

The following curves apply for 12-bit + sign mode

ADC12H030/ADC12H032/ADC12H034/ADC12H038, ADC12030/ADC12032/ADC12034/ADC12038

**Bipolar Spectral Response with 1 kHz Sine Wave Input**

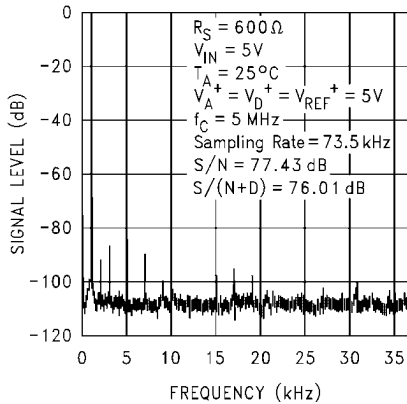

1135468

**Bipolar Spectral Response with 10 kHz Sine Wave Input**

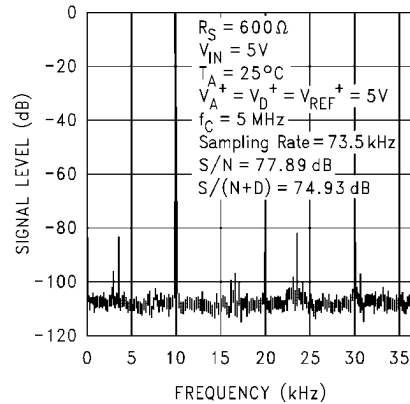

1135469

**Bipolar Spectral Response with 20 kHz Sine Wave Input**

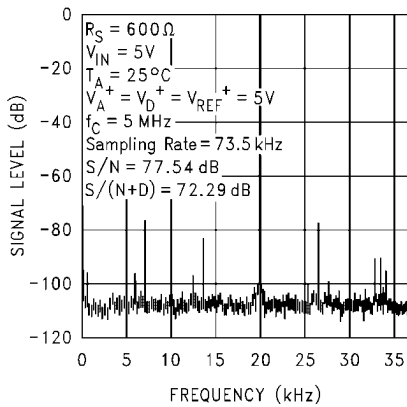

1135470

**Bipolar Spectral Response with 30 kHz Sine Wave Input**

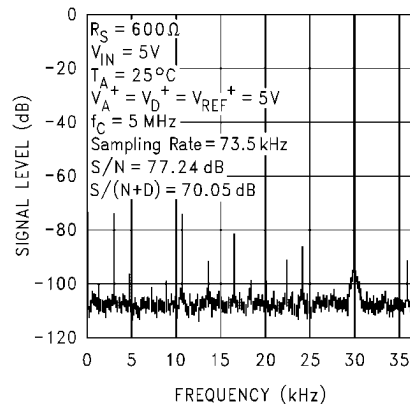

1135471

**Bipolar Spectral Response with 40 kHz Sine Wave Input**

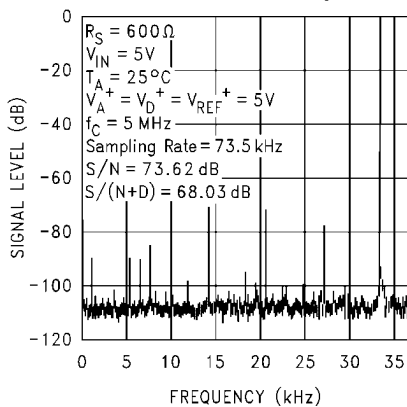

1135472

**Bipolar Spectral Response with 50 kHz Sine Wave Input**

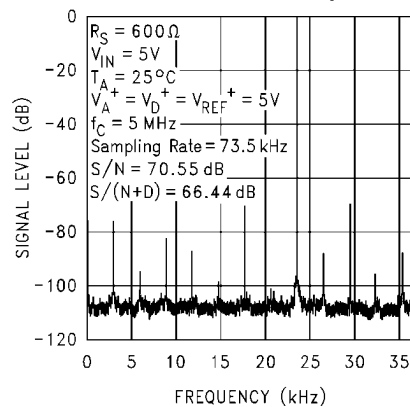

1135473

**Bipolar Spurious Free Dynamic Range**

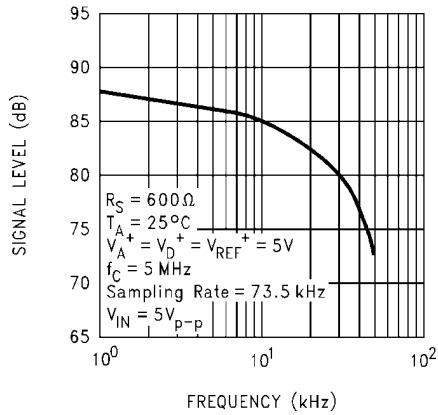

1135474

**Unipolar Signal-to-Noise Ratio vs. Input Frequency**

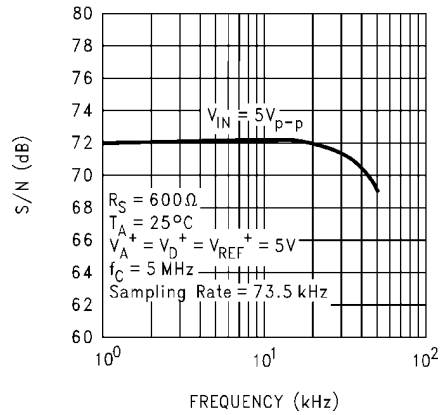

1135475

**Unipolar Signal-to-Noise + Distortion Ratio vs. Input Frequency**

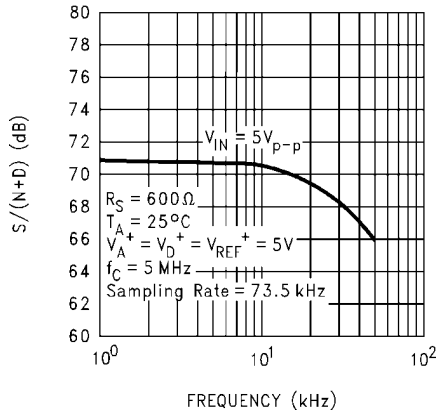

1135476

**Unipolar Signal-to-Noise + Distortion Ratio vs. Input Signal Level**

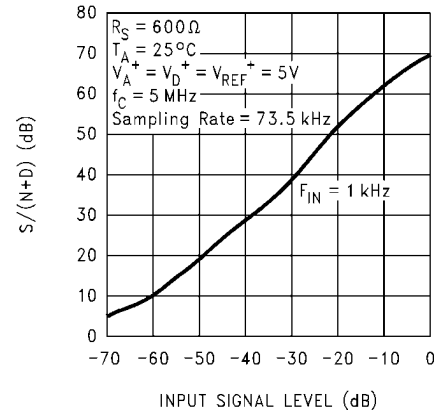

1135477

**Unipolar Spectral Response with 1 kHz Sine Wave Input**

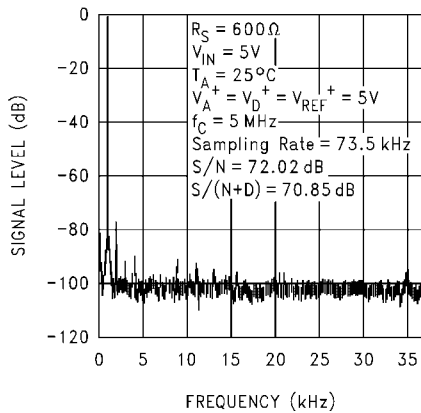

1135478

**Unipolar Spectral Response with 10 kHz Sine Wave Input**

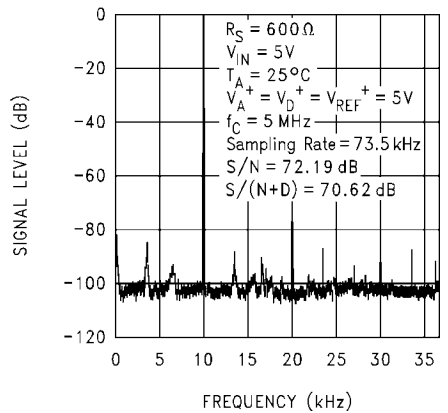

1135479

**Unipolar Spectral Response with 20 kHz Sine Wave Input**

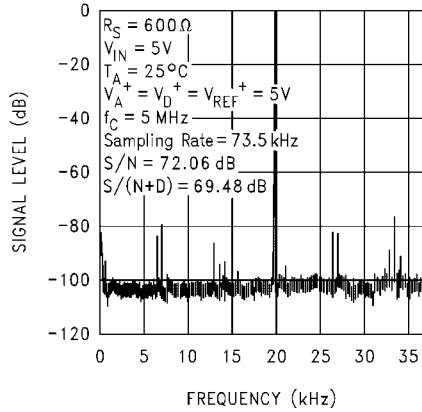

1135480

**Unipolar Spectral Response with 30 kHz Sine Wave Input**

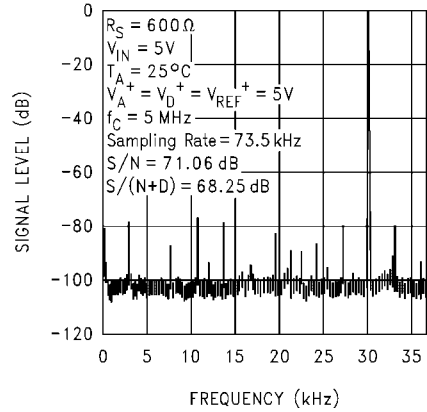

1135481

**Unipolar Spectral Response with 40 kHz Sine Wave Input**

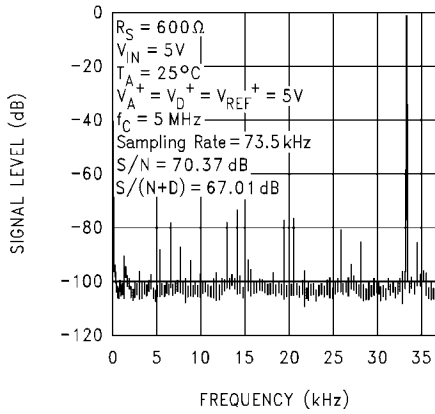

1135482

**Unipolar Spectral Response with 50 kHz Sine Wave Input**

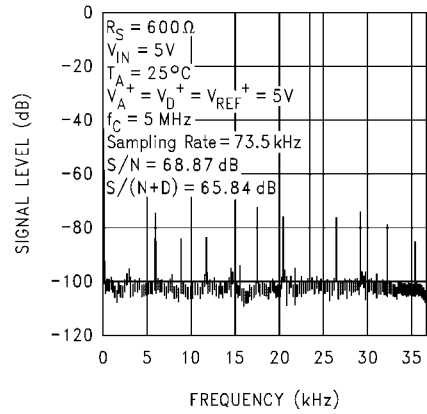

1135483

## Test Circuits

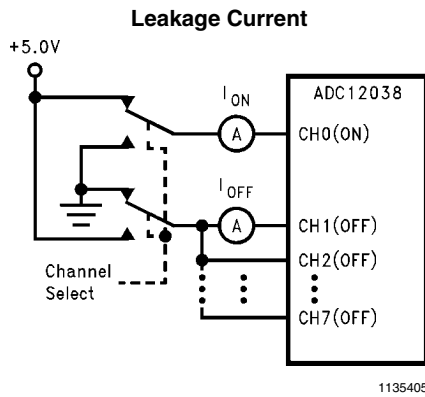
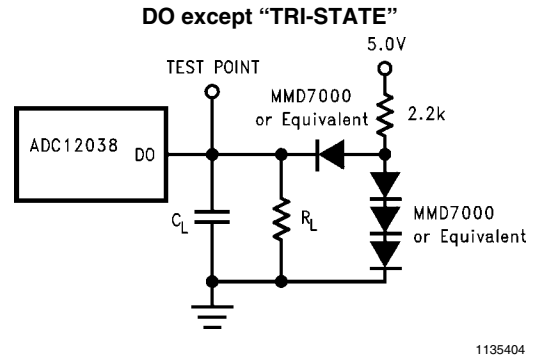
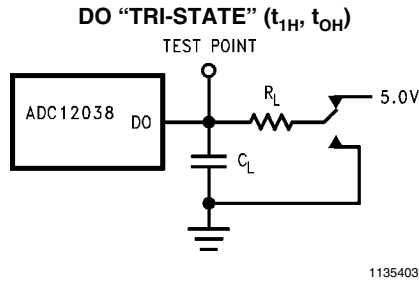

## Timing Diagrams

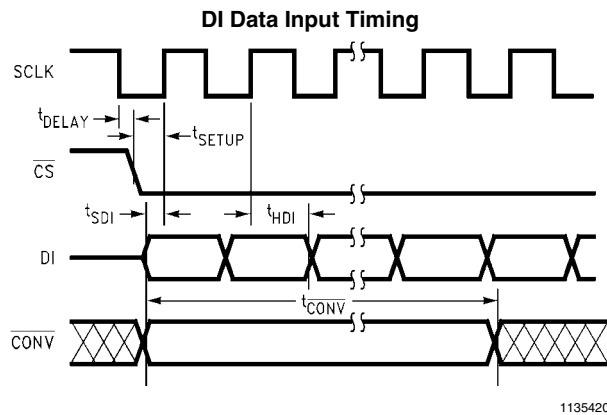
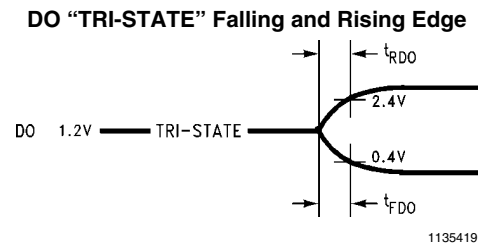
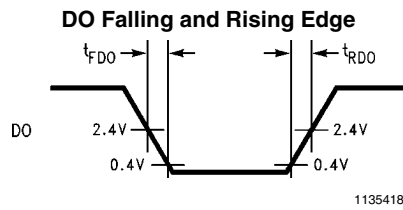

**DO Data Output Timing Using  $\overline{CS}$**

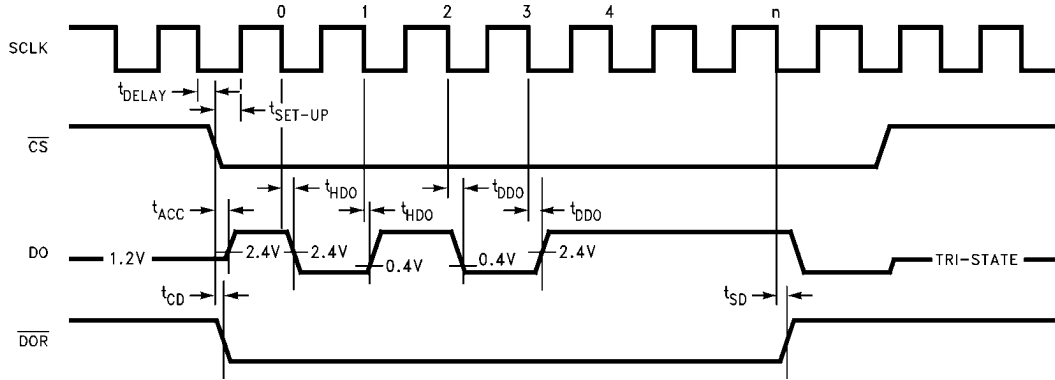

1135421

**DO Data Output Timing with  $\overline{CS}$  Continuously Low**

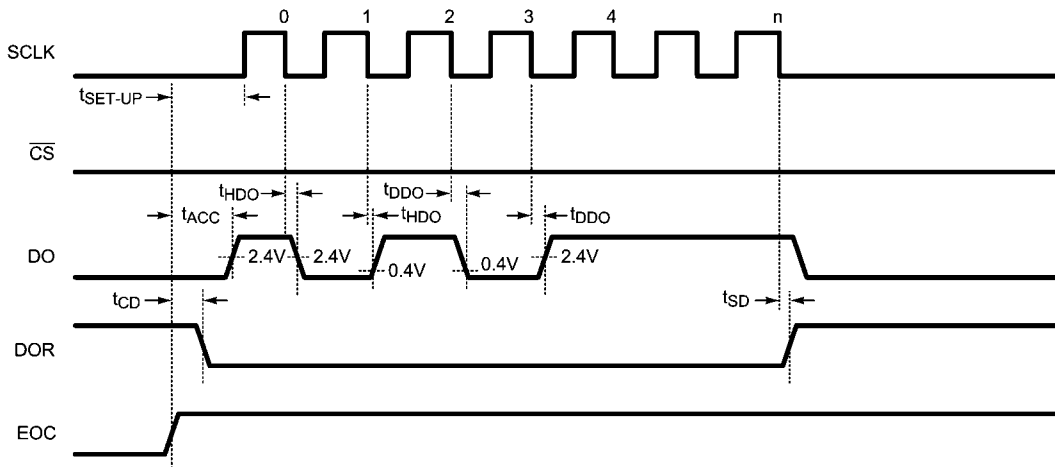

1135422

**ADC12038 Auto Cal or Auto Zero**

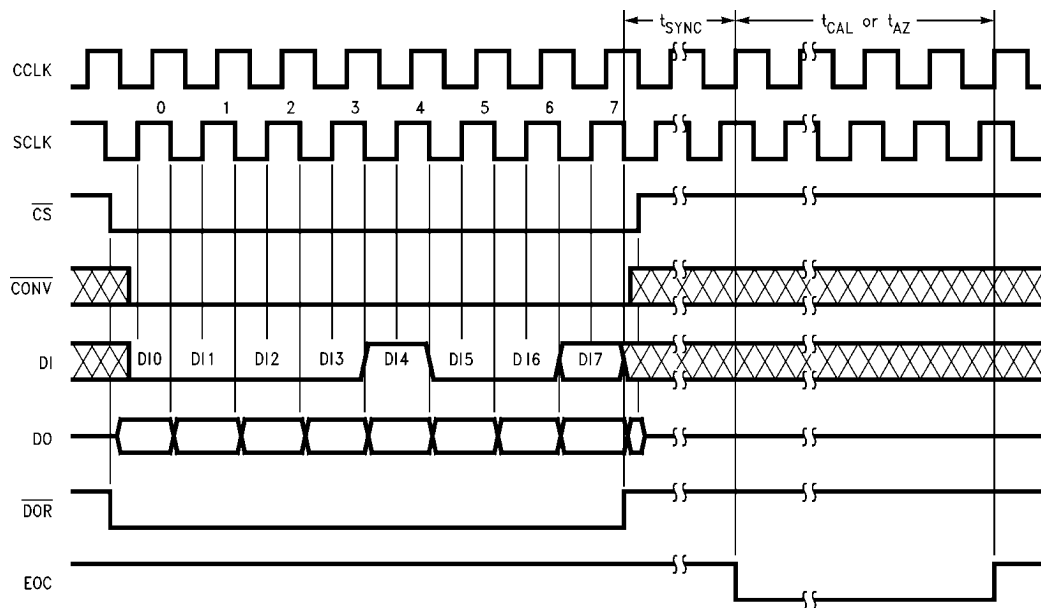

1135423

**Note:** DO output data is not valid during this cycle.

**ADC12038 Read Data without Starting a Conversion Using  $\overline{CS}$**

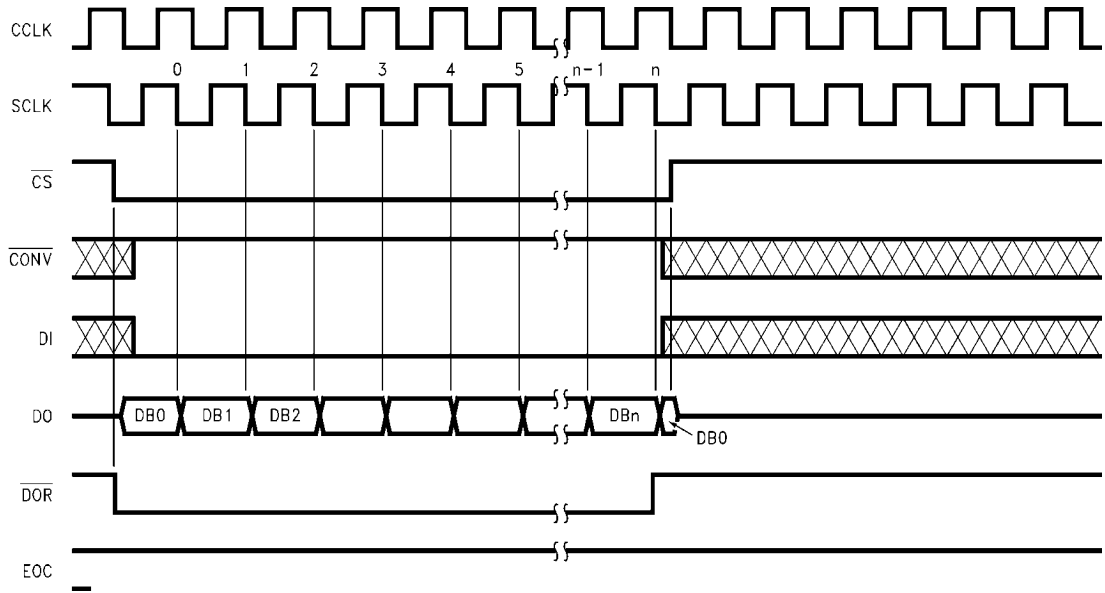

1135424

**ADC12038 Read Data without Starting a Conversion with  $\overline{CS}$  Continuously Low**

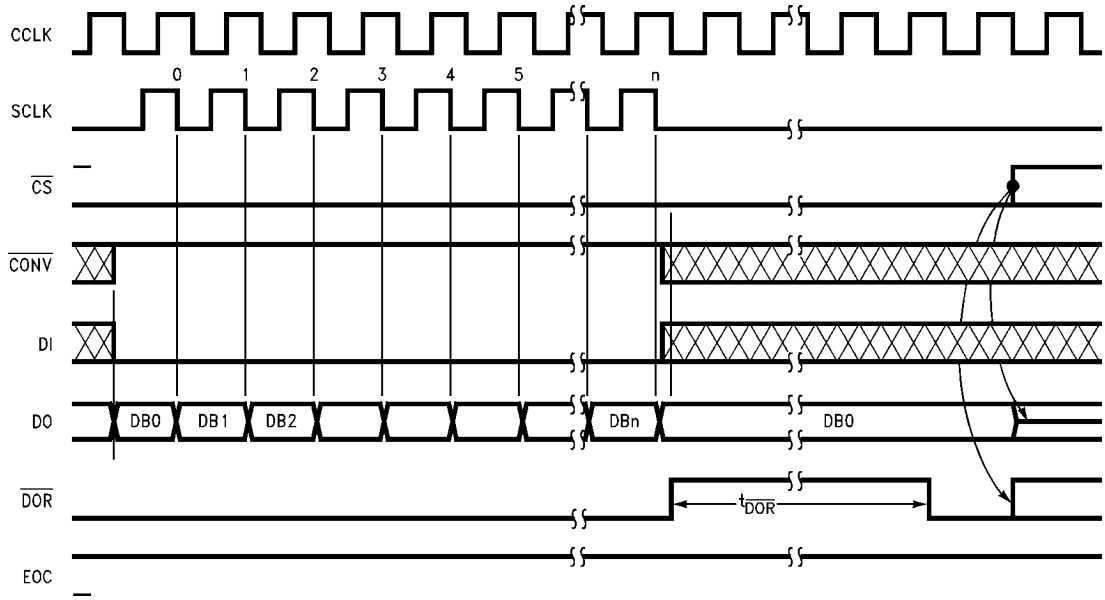

1135425

**ADC12038 Conversion Using  $\overline{\text{CS}}$  with 8-Bit Digital Output Format**

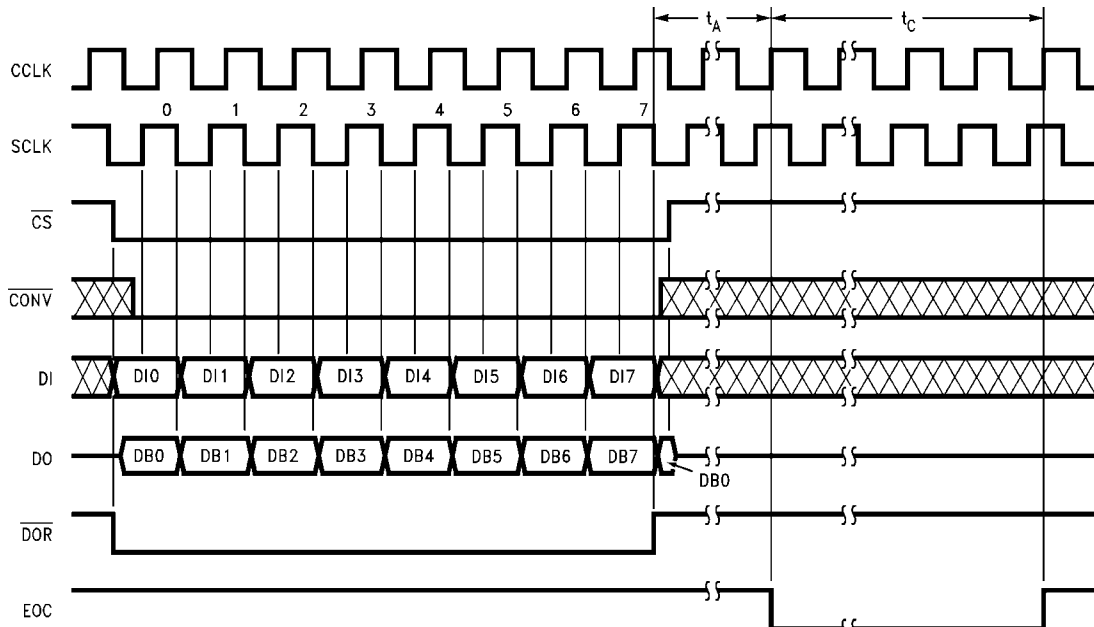

1135426

**ADC12038 Conversion Using  $\overline{\text{CS}}$  with 16-Bit Digital Output Format**

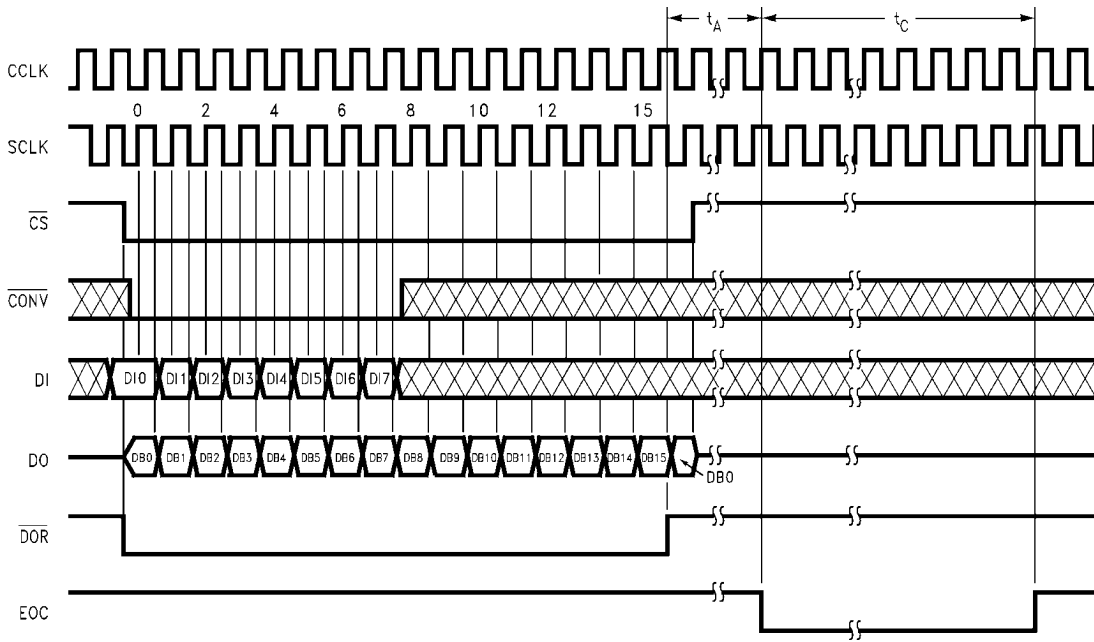

1135451

ADC12038 Conversion with  $\overline{CS}$  Continuously Low and 8-Bit Digital Output Format

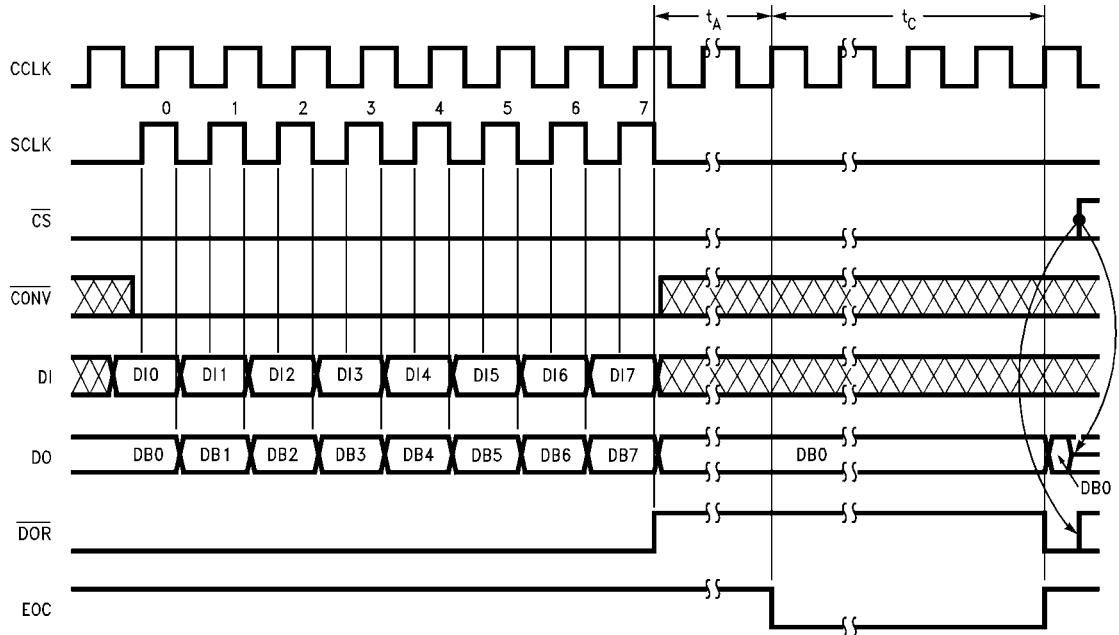

1135428

ADC12038 Conversion with  $\overline{CS}$  Continuously Low and 16-Bit Digital Output Format

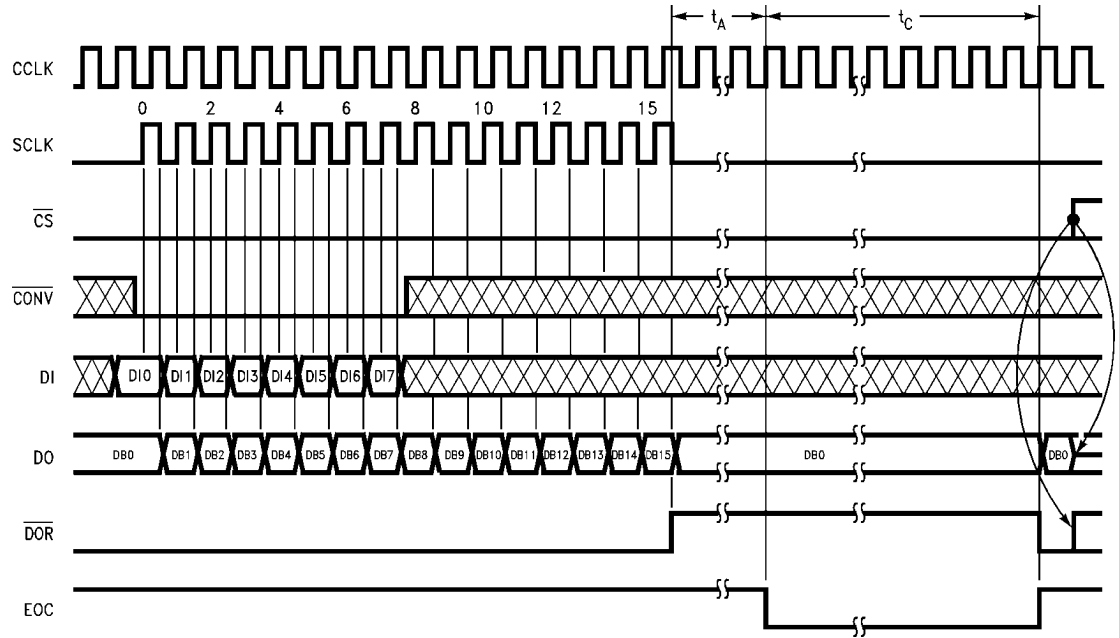

1135429

**ADC12038 Software Power Up/Down Using  $\overline{\text{CS}}$  with 16-Bit Digital Output Format**

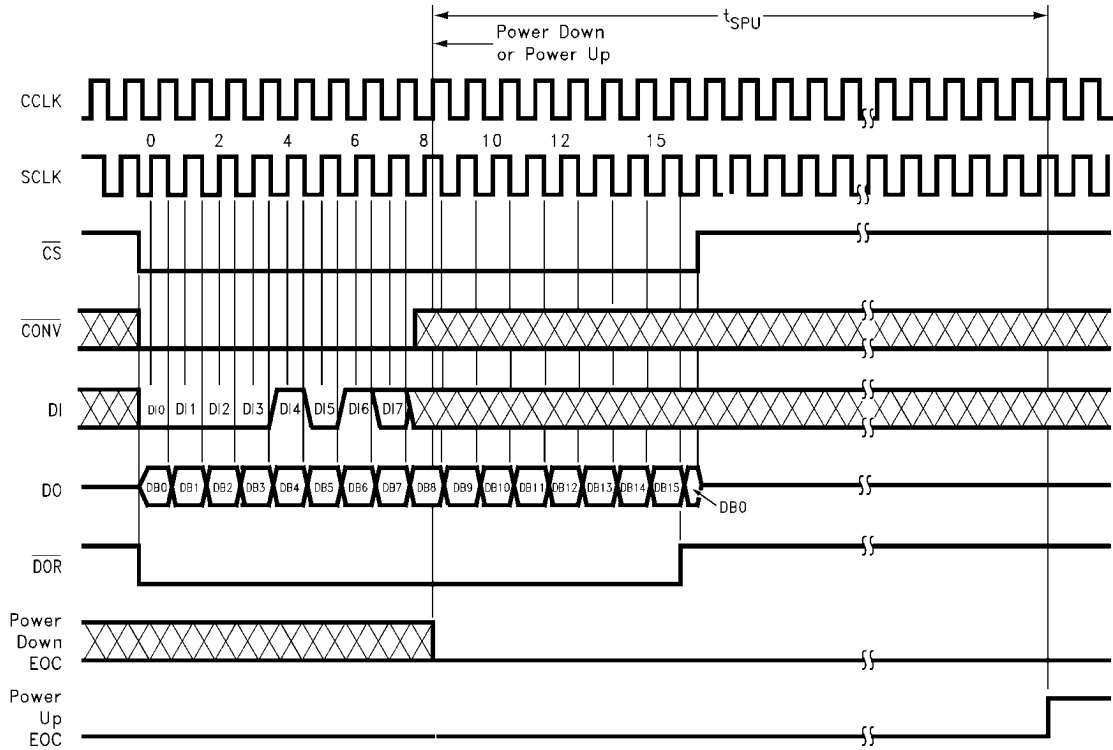

1135452

**ADC12038 Software Power Up/Down with  $\overline{\text{CS}}$  Continuously Low and 16-Bit Digital Output Format**

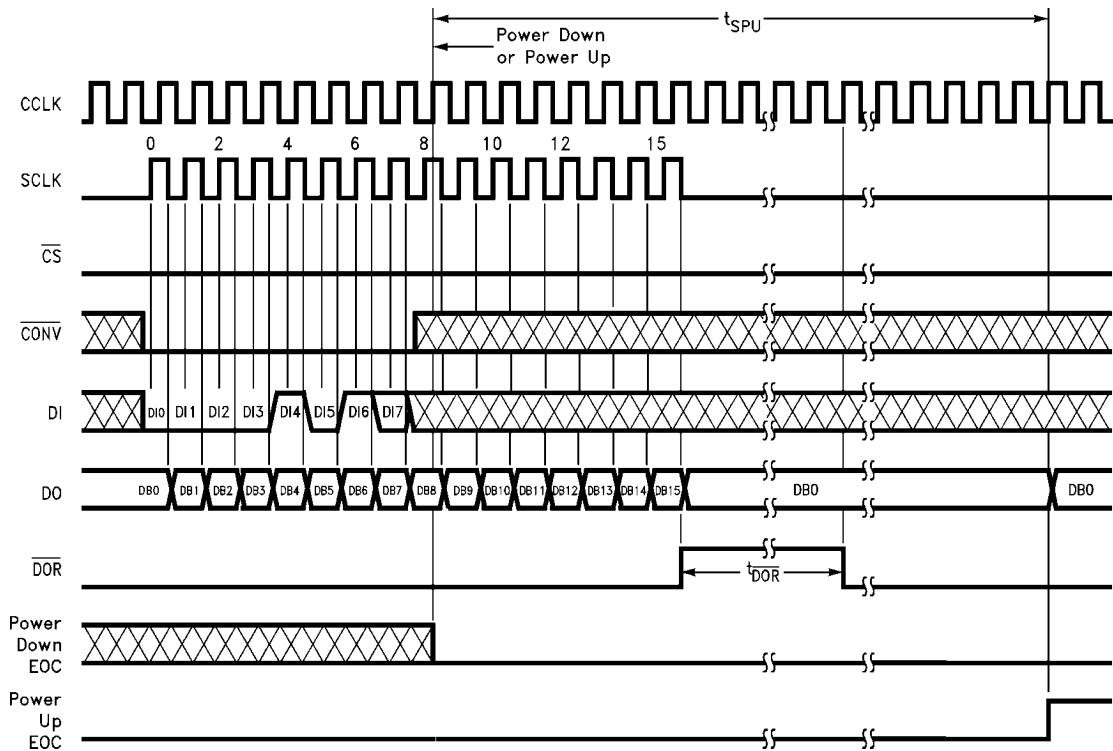

1135431

ADC12038 Hardware Power Up/Down

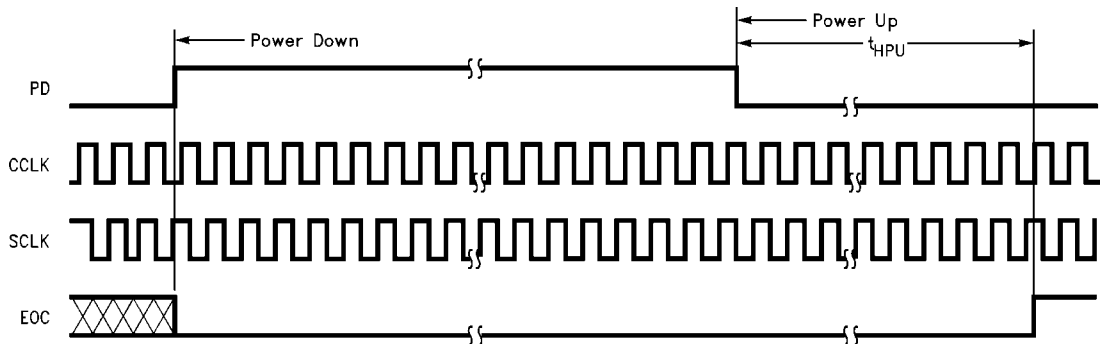

1135432

**Note:** Hardware power up/down may occur at any time. If PD is high while a conversion is in progress that conversion will be corrupted and erroneous data will be stored in the output shift register.

ADC12038 Configuration Modification—Example of a Status Read

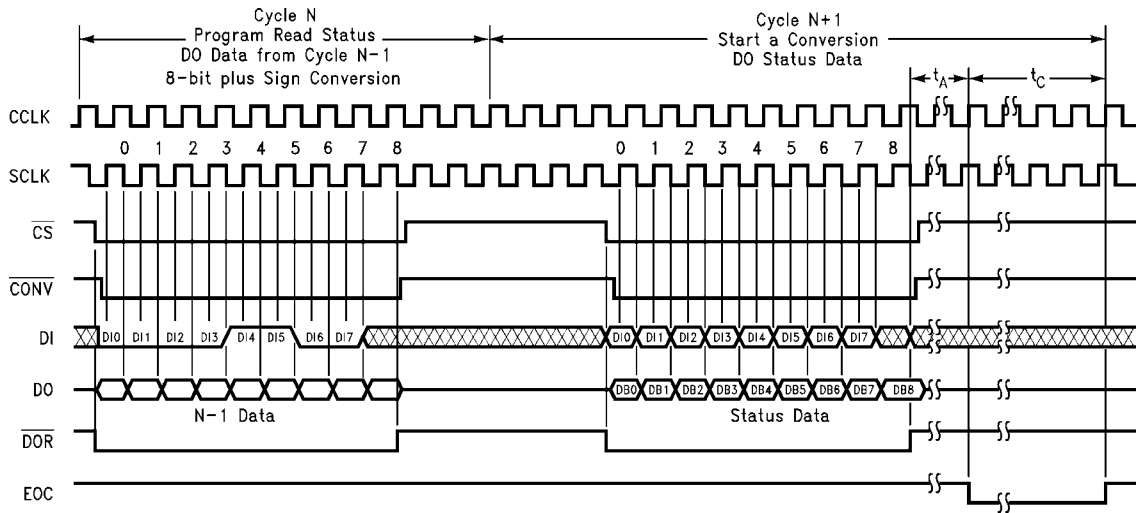

1135433

**Note:** In order for all 9 bits of Status Information to be accessible, the last conversion programmed before Cycle N needs to have a resolution of 8 bits plus sign, 12 bits, 12 bits plus sign, or greater.

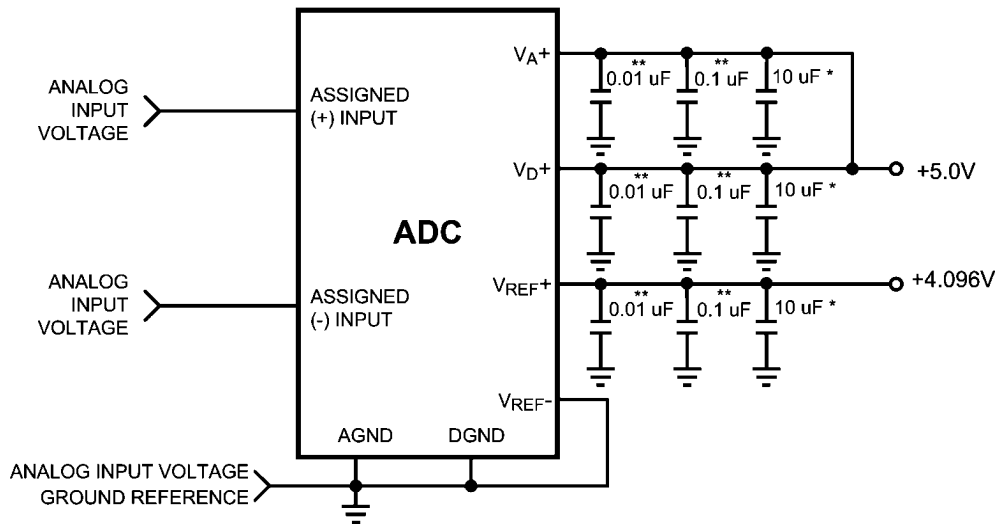

1135435

\*Tantalum  
\*\*Monolithic Ceramic or better

FIGURE 5. Recommended Power Supply Bypassing and Grounding

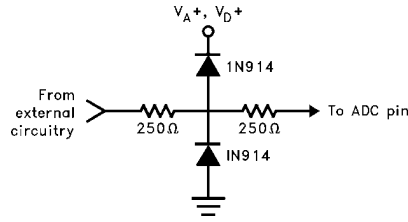

1135434

FIGURE 6. Protecting the MUXOUT1, MUXOUT2, A/DIN1 and A/DIN2 Analog Pins

## Format and Set-Up Tables

TABLE 1. Data Out Formats

| DO Formats   |           | DB0     | DB1  | DB2 | DB3 | DB4 | DB5  | DB6 | DB7 | DB8 | DB9  | DB10 | DB11 | DB12 | DB13 | DB14 | DB15 | DB16 |     |  |
|--------------|-----------|---------|------|-----|-----|-----|------|-----|-----|-----|------|------|------|------|------|------|------|------|-----|--|
| with Sign    | MSB First | 17 Bits | X    | X   | X   | X   | Sign | MSB | 10  | 9   | 8    | 7    | 6    | 5    | 4    | 3    | 2    | 1    | LSB |  |
|              |           | 13 Bits | Sign | MSB | 10  | 9   | 8    | 7   | 6   | 5   | 4    | 3    | 2    | 1    | LSB  |      |      |      |     |  |
|              |           | 9 Bits  | Sign | MSB | 6   | 5   | 4    | 3   | 2   | 1   | LSB  |      |      |      |      |      |      |      |     |  |
|              | LSB First | 17 Bits | LSB  | 1   | 2   | 3   | 4    | 5   | 6   | 7   | 8    | 9    | 10   | MSB  | Sign | X    | X    | X    | X   |  |
|              |           | 13 Bits | LSB  | 1   | 2   | 3   | 4    | 5   | 6   | 7   | 8    | 9    | 10   | MSB  | Sign |      |      |      |     |  |
|              |           | 9 Bits  | LSB  | 1   | 2   | 3   | 4    | 5   | 6   | MSB | Sign |      |      |      |      |      |      |      |     |  |
| without sign | MSB First | 16 Bits | 0    | 0   | 0   | 0   | MSB  | 10  | 9   | 8   | 7    | 6    | 5    | 4    | 3    | 2    | 1    | LSB  |     |  |
|              |           | 12 Bits | MSB  | 10  | 9   | 8   | 7    | 6   | 5   | 4   | 3    | 2    | 1    | LSB  |      |      |      |      |     |  |
|              |           | 8 Bits  | MSB  | 6   | 5   | 4   | 3    | 2   | 1   | LSB |      |      |      |      |      |      |      |      |     |  |
|              | LSB First | 16 Bits | LSB  | 1   | 2   | 3   | 4    | 5   | 6   | 7   | 8    | 9    | 10   | MSB  | 0    | 0    | 0    |      |     |  |
|              |           | 12 Bits | LSB  | 1   | 2   | 3   | 4    | 5   | 6   | 7   | 8    | 9    | 10   | MSB  |      |      |      |      |     |  |
|              |           | 8 Bits  | LSB  | 1   | 2   | 3   | 4    | 5   | 6   | MSB |      |      |      |      |      |      |      |      |     |  |

X = High or Low state.

TABLE 2. ADC12038 Multiplexer Addressing

| MUX Address |     |     |     | Analog Channel Addressed and Assignment with A/DIN1 tied to MUXOUT1 and A/DIN2 tied to MUXOUT2 |     |     |     |     |     |     |     |     | ADC Input Polarity Assignment |        | Multiplexer Output Channel Assignment |         | Mode         |
|-------------|-----|-----|-----|--|-----|-----|-----|-----|-----|-----|-----|-----|-------------------------------|--------|---------------------------------------|---------|--------------|
| DIO         | DI1 | DI2 | DI3 | CH0  | CH1 | CH2 | CH3 | CH4 | CH5 | CH6 | CH7 | COM | A/DIN1                        | A/DIN2 | MUXOUT1                               | MUXOUT2 |              |
| L           | L   | L   | L   | +  | -   |     |     |     |     |     |     |     | +                             | -      | CH0                                   | CH1     | Differential |
| L           | L   | L   | H   |  |     | +   | -   |     |     |     |     |     | +                             | -      | CH2                                   | CH3     |              |
| L           | L   | H   | L   |  |     |     |     | +   | -   |     |     |     | +                             | -      | CH4                                   | CH5     |              |
| L           | L   | H   | H   |  |     |     |     |     |     | +   | -   |     | +                             | -      | CH6                                   | CH7     |              |
| L           | H   | L   | L   | -  | +   |     |     |     |     |     |     |     | -                             | +      | CH0                                   | CH1     |              |
| L           | H   | L   | H   |  |     | -   | +   |     |     |     |     |     | -                             | +      | CH2                                   | CH3     |              |
| L           | H   | H   | L   |  |     |     |     | -   | +   |     |     |     | -                             | +      | CH4                                   | CH5     |              |
| L           | H   | H   | H   |  |     |     |     |     |     | -   | +   |     | -                             | +      | CH6                                   | CH7     |              |
| H           | L   | L   | L   | +  |     |     |     |     |     |     |     | -   | +                             | -      | CH0                                   | COM     | Single-Ended |
| H           | L   | L   | H   |  |     | +   |     |     |     |     |     | -   | +                             | -      | CH2                                   | COM     |              |
| H           | L   | H   | L   |  |     |     |     | +   |     |     |     | -   | +                             | -      | CH4                                   | COM     |              |
| H           | L   | H   | H   |  |     |     |     |     |     | +   |     | -   | +                             | -      | CH6                                   | COM     |              |
| H           | H   | L   | L   |  | +   |     |     |     |     |     |     | -   | +                             | -      | CH1                                   | COM     |              |
| H           | H   | L   | H   |  |     |     | +   |     |     |     |     | -   | +                             | -      | CH3                                   | COM     |              |
| H           | H   | H   | L   |  |     |     |     |     | +   |     |     | -   | +                             | -      | CH5                                   | COM     |              |
| H           | H   | H   | H   |  |     |     |     |     |     | +   |     | -   | +                             | -      | CH7                                   | COM     |              |

TABLE 3. ADC12034 Multiplexer Addressing

| MUX Address |     |     | Analog Channel Addressed and Assignment with A/DIN1 tied to MUXOUT1 and A/DIN2 tied to MUXOUT2 |     |     |     |     | ADC Input Polarity Assignment |        | Multiplexer Output Channel Assignment |         | Mode         |
|-------------|-----|-----|--|-----|-----|-----|-----|-------------------------------|--------|---------------------------------------|---------|--------------|
| DIO         | DI1 | DI2 | CH0  | CH1 | CH2 | CH3 | COM | A/DIN1                        | A/DIN2 | MUXOUT1                               | MUXOUT2 |              |
| L           | L   | L   | +  | -   |     |     |     | +                             | -      | CH0                                   | CH1     | Differential |
| L           | L   | H   |  |     | +   | -   |     | +                             | -      | CH2                                   | CH3     |              |
| L           | H   | L   | -  | +   |     |     |     | -                             | +      | CH0                                   | CH1     |              |
| L           | H   | H   |  |     | -   | +   |     | -                             | +      | CH2                                   | CH3     |              |
| H           | L   | L   | +  |     |     |     |     | -                             | +      | CH0                                   | COM     | Single-Ended |
| H           | L   | H   |  |     | +   |     |     | -                             | +      | CH2                                   | COM     |              |
| H           | H   | L   |  | +   |     |     |     | -                             | +      | CH1                                   | COM     |              |
| H           | H   | H   |  |     |     | +   |     | -                             | +      | CH3                                   | COM     |              |

**TABLE 4. ADC12032 and ADC12030 Multiplexer Addressing**

| MUX Address |     | Analog Channel Addressed and Assignment with A/DIN1 tied to MUXOUT1 and A/DIN2 tied to MUXOUT2 |     |     | ADC Input Polarity Assignment |        | Multiplexer Output Channel Assignment |         | Mode         |
|-------------|-----|--|-----|-----|-------------------------------|--------|---------------------------------------|---------|--------------|
| DI0         | DI1 | CH0  | CH1 | COM | A/DIN1                        | A/DIN2 | MUXOUT1                               | MUXOUT2 |              |
| L           | L   | +  | -   |     | +                             | -      | CH0                                   | CH1     | Differential |
| L           | H   | -  | +   |     | -                             | +      | CH0                                   | CH1     |              |
| H           | L   | +  |     | -   | +                             | -      | CH0                                   | COM     | Single-Ended |
| H           | H   |  | +   | -   | +                             | -      | CH1                                   | COM     |              |

**Note:** ADC12030 and ADC12H030 do not have A/DIN1, A/DIN2, MUX-OUT1 and MUXOUT2 pins.

**TABLE 5. Mode Programming**

| ADC12038              | DI0                        | DI1 | DI2 | DI3 | DI4 | DI5 | DI6 | DI7 | Mode Selected (Current)                   | DO Format (next Conversion Cycle) |
|-----------------------|----------------------------|-----|-----|-----|-----|-----|-----|-----|---|-----------------------------------|
| ADC12034              | DI0                        | DI1 | DI2 |     | DI3 | DI4 | DI5 | DI6 |   |                                   |
| ADC12030 and ADC12032 | DI0                        | DI1 |     |     | DI2 | DI3 | DI4 | DI5 |   |                                   |
|                       | See Tables 2, 3 or Table 4 |     |     |     | L   | L   | L   | L   | 12 Bit Conversion                         | 12 or 13 Bit MSB First            |
|                       | See Tables 2, 3 or Table 4 |     |     |     | L   | L   | L   | H   | 12 Bit Conversion                         | 16 or 17 Bit MSB First            |
|                       | See Tables 2, 3 or Table 4 |     |     |     | L   | L   | H   | L   | 8 Bit Conversion                          | 8 or 9 Bit MSB First              |
|                       | L                          | L   | L   | L   | L   | L   | H   | H   | 12 Bit Conversion of Full-Scale           | 12 or 13 Bit MSB First            |
|                       | See Tables 2, 3 or Table 4 |     |     |     | L   | H   | L   | L   | 12 Bit Conversion                         | 12 or 13 Bit LSB First            |
|                       | See Tables 2, 3 or Table 4 |     |     |     | L   | H   | L   | H   | 12 Bit Conversion                         | 16 or 17 Bit LSB First            |
|                       | See Tables 2, 3 or Table 4 |     |     |     | L   | H   | H   | L   | 8 Bit Conversion                          | 8 or 9 Bit LSB First              |
|                       | L                          | L   | L   | L   | L   | H   | H   | H   | 12 Bit Conversion of Offset               | 12 or 13 Bit LSB First            |
|                       | L                          | L   | L   | L   | H   | L   | L   | L   | Auto Cal                                  | No Change                         |
|                       | L                          | L   | L   | L   | H   | L   | L   | H   | Auto Zero                                 | No Change                         |
|                       | L                          | L   | L   | L   | H   | L   | H   | L   | Power Up                                  | No Change                         |
|                       | L                          | L   | L   | L   | H   | L   | H   | H   | Power Down                                | No Change                         |
|                       | L                          | L   | L   | L   | H   | H   | L   | L   | Read Status Register                      | No Change                         |
|                       | L                          | L   | L   | L   | H   | H   | L   | H   | Data Out without Sign                     | No Change                         |
|                       | H                          | L   | L   | L   | H   | H   | L   | H   | Data Out with Sign                        | No Change                         |
|                       | L                          | L   | L   | L   | H   | H   | H   | L   | Acquisition Time—6 CCLK Cycles            | No Change                         |
|                       | L                          | H   | L   | L   | H   | H   | H   | L   | Acquisition Time—10 CCLK Cycles           | No Change                         |
|                       | H                          | L   | L   | L   | H   | H   | H   | L   | Acquisition Time—18 CCLK Cycles           | No Change                         |
|                       | H                          | H   | L   | L   | H   | H   | H   | L   | Acquisition Time—34 CCLK Cycles           | No Change                         |
|                       | L                          | L   | L   | L   | H   | H   | H   | H   | User Mode                                 | No Change                         |
|                       | H                          | X   | X   | X   | H   | H   | H   | H   | Test Mode (CH1–CH7 become Active Outputs) | No Change                         |

**Note:** The ADC powers up with no Auto Cal, no Auto Zero, 10 CCLK acquisition time, 12-bit + sign conversion, power up, 12- or 13-bit MSB first, and user mode. X = Don't Care

**TABLE 6. Conversion/Read Data Only Mode Programming**

| CS | CONV | PD | Mode   |
|----|------|----|--|
| L  | L    | L  | See Table 5 for Mode                           |
| L  | H    | L  | Read Only (Previous DO Format). No Conversion. |
| H  | X    | L  | Idle   |
| X  | X    | H  | Power Down                                     |

X = Don't Care

**TABLE 7. Status Register**

| Status Bit Location | DB0   | DB1   | DB2  | DB3                                   | DB4                                    | DB5                                    | DB6  | DB7   | DB8  |
|---------------------|---|---|--|---------------------------------------|--|--|--|---|--|
| Status Bit          | PU  | PD  | Cal  | 8 or 9                                | 12 or 13                               | 16 or 17                               | Sign   | Justification   | Test Mode  |
| <b>Function</b>     | <b>Device Status</b>                                |   |  | <b>DO Output Format Status</b>        |  |  |  |   |  |
|                     | “High” indicates a Power Up Sequence is in progress | “High” indicates a Power Down Sequence is in progress | “High” indicates an Auto Cal Sequence is in progress | “High” indicates an 8 or 9 bit format | “High” indicates a 12 or 13 bit format | “High” indicates a 16 or 17 bit format | “High” indicates that the sign bit is included. When “Low” the sign bit is not included. | When “High” the conversion result will be output MSB first. When “Low” the result will be output LSB first. | When “High” the device is in test mode. When “Low” the device is in user mode. |

# Applications Information

## 1.0 DIGITAL INTERFACE

### 1.1 Interface Concepts

The example in *Figure 7* shows a typical sequence of events after the power is applied to the ADC12030/2/4/8:

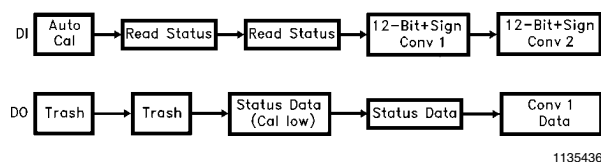

**FIGURE 7. Typical Power Supply Power Up Sequence**

The first instruction input to the ADC via DI initiates Auto Cal. The data output on DO at that time is meaningless and is completely random. To determine whether the Auto Cal has been completed, a read status instruction should be issued to the ADC. Again the data output at that time has no significance since the Auto Cal procedure modifies the data in the output shift register. To retrieve the status information, an additional read status instruction should be issued to the ADC. At this time the status data is available on DO. If the Cal signal in the status word is low, Auto Cal has been completed. Therefore, the next instruction issued can start a conversion. The data output at this time is again status information.

To keep noise from corrupting the conversion, status can not be read during a conversion. If  $\overline{CS}$  is strobed and is brought low during a conversion, that conversion is prematurely ended. EOC can be used to determine the end of a conversion or the ADC controller can keep track in software of when it would be appropriate to communicate to the ADC again. Once it has been determined that a conversion has completed, another instruction can be transmitted to the ADC. The data from this conversion can be accessed when the next instruction is issued to the ADC.

Note, when  $\overline{CS}$  is low continuously it is important to transmit the exact number of SCLK cycles, as shown in the timing diagrams. Not doing so will desynchronize the serial communication to the ADC. (See *Section 1.3  $\overline{CS}$  Low Continuously Considerations*.)

### 1.2 Changing Configuration

The configuration of the ADC12030/2/4/8 on power up defaults to 12-bit plus sign resolution, 12- or 13-bit MSB First, 10 CCLK acquisition time, user mode, no Auto Cal, no Auto Zero, and power up mode. Changing the acquisition time and turning the sign bit on and off requires an 8-bit instruction to be issued to the ADC. This instruction will not start a conversion. The instructions that select a multiplexer address and format the output data do start a conversion. *Figure 8* describes an example of changing the configuration of the ADC12030/2/4/8.

During I/O sequence 1, the instruction at DI configures the ADC12030/2/4/8 to do a conversion with 12-bit +sign resolution. Notice that when the 6 CCLK Acquisition and Data Out without Sign instructions are issued to the ADC, I/O sequences 2 and 3, a new conversion is not started. The data output during these instructions is from conversion N which was started during I/O sequence 1. The Configuration Modification timing diagram describes in detail the sequence of events necessary for a Data Out without Sign, Data Out with Sign, or 6/10/18/34 CCLK Acquisition time mode selection.

*Table 5* describes the actual data necessary to be input to the ADC to accomplish this configuration modification. The next instruction issued to the ADC, shown in *Figure 8*, starts conversion N+1 with 8 bits of resolution formatted MSB first. Again the data output during this I/O cycle is the data from conversion N.

The number of SCLKs applied to the ADC during any conversion I/O sequence should vary in accord with the data out word format chosen during the previous conversion I/O sequence. The various formats and resolutions available are shown in *Table 1*. In *Figure 8*, since 8-bit without sign, MSB first format was chosen during I/O sequence 4, the number of SCLKs required during I/O sequence 5 is eight. In the following I/O sequence the format changes to 12-bit without sign MSB first; therefore the number of SCLKs required during I/O sequence 6 changes accordingly to 12.

### 1.3 $\overline{CS}$ Low Continuously Considerations

When  $\overline{CS}$  is continuously low, it is important to transmit the exact number of SCLK pulses that the ADC expects. Not doing so will desynchronize the serial communications to the ADC. When the supply power is first applied to the ADC, it will expect to see **13 SCLK pulses** for each I/O transmission. The number of SCLK pulses that the ADC expects to see is the same as the digital output word length. The digital output word length is controlled by the Data Out (DO) format. The DO format maybe changed any time a conversion is started or when the sign bit is turned on or off. The table below details out the number of clock periods required for different DO formats:

| DO Format               |          | Number of SCLKs Expected |
|-------------------------|----------|--------------------------|
| 8-Bit MSB or LSB First  | SIGN OFF | 8                        |
|                         | SIGN ON  | 9                        |
| 12-Bit MSB or LSB First | SIGN OFF | 12                       |
|                         | SIGN ON  | 13                       |
| 16-Bit MSB or LSB first | SIGN OFF | 16                       |
|                         | SIGN ON  | 17                       |

If erroneous SCLK pulses desynchronize communications, the simplest way to recover is by cycling the power supply to the device. Not being able to easily resynchronize the device is a shortcoming of leaving  $\overline{CS}$  low continuously.

The number of clock pulses required for an I/O exchange may be different for the case when  $\overline{CS}$  is left low continuously vs. the case when  $\overline{CS}$  is cycled. Take the I/O sequence detailed in *Figure 7* (Typical Power Supply Sequence) as an example. The table below lists the number of SCLK pulses required for each instruction:

| Instruction          | $\overline{CS}$ Low Continuously | $\overline{CS}$ Strobed |
|----------------------|----------------------------------|-------------------------|
| Auto Cal             | 13 SCLKs                         | 8 SCLKs                 |
| Read Status          | 13 SCLKs                         | 8 SCLKs                 |
| Read Status          | 13 SCLKs                         | 8 SCLKs                 |
| 12-Bit + Sign Conv 1 | 13 SCLKs                         | 8 SCLKs                 |
| 12-Bit + Sign Conv 2 | 13 SCLKs                         | 13 SCLKs                |

### 1.4 Analog Input Channel Selection

The data input at DI also selects the channel configuration (see *Tables 2, 3, 4, 5*). In *Figure 8* the only times when the channel configuration could be modified is during I/O sequences 1, 4, 5 and 6. Input channels are reselected before

the start of each new conversion. Shown below is the data bit stream required at DI, during I/O sequence number 4 in *Figure 8*, to set CH1 as the positive input and CH0 as the negative input for the different versions of ADCs:

| Part Number           | DI Data |     |     |     |     |     |     |     |
|-----------------------|---------|-----|-----|-----|-----|-----|-----|-----|
|                       | DI0     | DI1 | DI2 | DI3 | DI4 | DI5 | DI6 | DI7 |
| ADC12H030<br>ADC12030 | L       | H   | L   | L   | H   | L   | X   | X   |
| ADC12H032<br>ADC12032 | L       | H   | L   | L   | H   | L   | X   | X   |
| ADC12H034<br>ADC12034 | L       | H   | L   | L   | L   | H   | L   | X   |
| ADC12H038<br>ADC12038 | L       | H   | L   | L   | L   | L   | H   | L   |

Where X can be a logic high (H) or low (L).

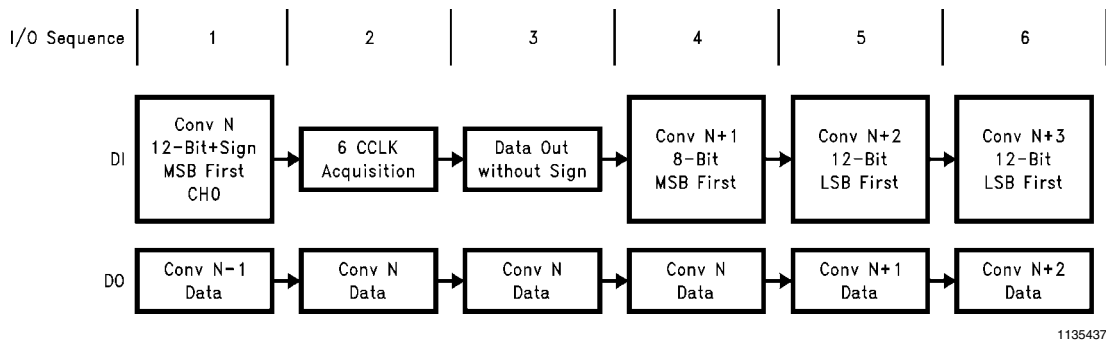

FIGURE 8. Changing the ADC's Conversion Configuration

### 1.6 User Mode and Test Mode

An instruction may be issued to the ADC to put it into test mode, which is used by the manufacturer to verify complete functionality of the device. During test mode CH0–CH7 become active outputs. If the device is inadvertently put into the test mode with  $\overline{CS}$  continuously low, the serial communications may be desynchronized. Synchronization may be regained by cycling the power supply voltage to the device. Cycling the power supply voltage will also set the device into user mode. If  $\overline{CS}$  is used in the serial interface, the ADC may be queried to see what mode it is in. This is done by issuing a “read STATUS register” instruction to the ADC. When bit 9 of the status register is high, the ADC is in test mode; when bit 9 is low the ADC, is in user mode. As an alternative to cycling the power supply, an instruction sequence may be used to return the device to user mode. This instruction sequence must be issued to the ADC using  $\overline{CS}$ . The following table lists the instructions required to return the device to user mode. Note that this **entire sequence**, including both Test Mode and User Mode values, should be sent to recover from the test mode.

### 1.5 Power Up/Down

The ADC may be powered down by taking the PD pin HIGH or by the instruction input at DI (see *Table 5* and *Table 6*, and the Power Up/Down timing diagrams). When the ADC is powered down in this way, the ADC conversion circuitry is deactivated but the digital I/O circuitry is kept active.

Hardware power up/down is controlled by the state of the PD pin. Software power-up/down is controlled by the instruction issued to the ADC. If a software power up instruction is issued to the ADC while a hardware power down is in effect (PD pin high) the device will remain in the power-down state. If a software power down instruction is issued to the ADC while a hardware power up is in effect (PD pin low), the device will power down. When the device is powered down by software, it may be powered up by either issuing a software power up instruction or by taking PD pin high and then low. If the power down command is issued during a conversion, that conversion is interrupted, so the data output after power up cannot be relied upon.

| Instruction                 | DI Data |        |        |     |     |        |        |        |
|-----------------------------|---------|--------|--------|-----|-----|--------|--------|--------|
|                             | DI0     | DI1    | DI2    | DI3 | DI4 | DI5    | DI6    | DI7    |
| <b>TEST MODE</b>            | H       | X      | X      | X   | H   | H      | H      | H      |
| Reset                       | L       | L      | L      | L   | H   | H      | H      | L      |
| Test Mode Instructions      | L       | L      | L      | L   | H   | L      | H      | H      |
| <b>USER MODE</b>            | L       | L      | L      | L   | H   | H      | H      | H      |
| Power Up                    | L       | L      | L      | L   | H   | L      | H      | L      |
| Set DO with or without Sign | H or L  | L      | L      | L   | H   | H      | L      | H      |
| Set Acquisition Time        | H or L  | H or L | L      | L   | H   | H      | H      | L      |
| Start a Conversion          | H or L  | H or L | H or L | L   | L   | H or L | H or L | H or L |

X = Don't Care

The power up, data with or without sign, and acquisition time instructions should be resent after returning to the user mode. This is to ensure that the ADC is in the required state before a conversion is started.

### 1.7 Reading the Data Without Starting a Conversion

The data from a particular conversion may be accessed without starting a new conversion by ensuring that the  $\overline{\text{CONV}}$  line is taken high during the I/O sequence. See the Read Data timing diagrams. Table 6 describes the operation of the  $\overline{\text{CONV}}$  pin. It is not necessary to read the data as soon as  $\overline{\text{DOR}}$  goes low. The data will remain in the output register if  $\overline{\text{CS}}$  is brought high right after  $\overline{\text{DOR}}$  goes high. A single conversion may be read as many times as desired before  $\overline{\text{CS}}$  is brought low.

### 1.8 Brown Out Conditions

When the supply voltage dips below about 2.7V, the internal registers, including the calibration coefficients and all of the other registers, may lose their contents. When this happens the ADC will not perform as expected or not at all after power

is fully restored. While writing the desired information to all registers and performing a calibration *might sometimes* cause recovery to full operation, the only sure recovery method is to reduce the supply voltage to below 0.5V, then reprogram the ADC and perform a calibration after power is fully restored.

### 2.0 THE ANALOG MULTIPLEXER

For the ADC12038, the analog input multiplexer can be configured with 4 differential channels or 8 single ended channels with the COM input as the zero reference or any combination thereof (see Figure 9). The difference between the voltages at the  $V_{\text{REF}^+}$  and  $V_{\text{REF}^-}$  pins determines the input voltage span ( $V_{\text{REF}}$ ). The analog input voltage range is 0 to  $V_{\text{A}^+}$ . Negative digital output codes result when  $V_{\text{IN}^-} > V_{\text{IN}^+}$ . The actual voltage at  $V_{\text{IN}^-}$  or  $V_{\text{IN}^+}$  cannot go below AGND.



FIGURE 9. Input Multiplexer Options

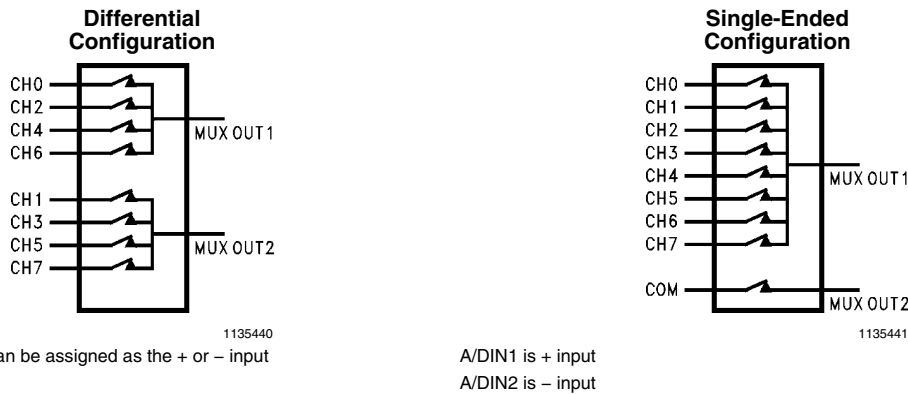

FIGURE 10. MUXOUT connections for multiplexer option

CH0, CH2, CH4, and CH6 can be assigned to the MUXOUT1 pin in the differential configuration, while CH1, CH3, CH5, and CH7 can be assigned to the MUXOUT2 pin. In the differential configuration, the analog inputs are paired as follows: CH0 with CH1, CH2 with CH3, CH4 with CH5 and CH6 with CH7. The A/DIN1 and A/DIN2 pins can be assigned positive or negative polarity.

With the single-ended multiplexer configuration, CH0 through CH7 can be assigned to the MUXOUT1 pin. The COM pin is always assigned to the MUXOUT2 pin. A/DIN1 is assigned as

the positive input; A/DIN2 is assigned as the negative input. (See Figure 10).

The Multiplexer assignment tables for these ADCs (Tables 2, 3, 4) summarize the aforementioned functions for the different versions of ADCs.

#### 2.1 Biasing for Various Multiplexer Configurations

Figure 11 is an example of device connections for single-ended operation. The sign bit is always low. The digital output range is 0 0000 0000 0000 to 0 1111 1111 1111. One LSB is equal to 1 mV (4.1V/4096 LSBs).

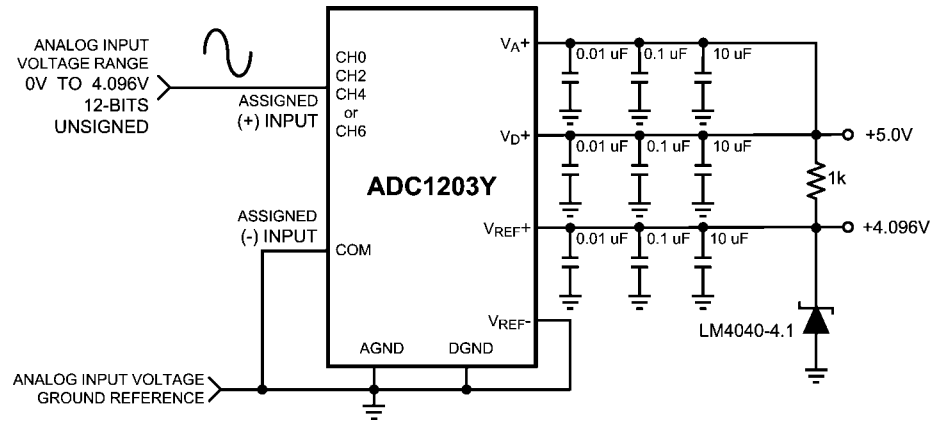

1135446

FIGURE 11. Single-Ended Biasing

For pseudo-differential signed operation, the circuit of shows a signal AC coupled to the ADC. This gives a digital output range of  $-4096$  to  $+4095$ . With a  $2.5V$  reference,  $1$  LSB is equal to  $610 \mu V$ . Although the ADC is not production tested with a  $2.5V$  reference, when  $V_{A+}$  and  $V_{D+}$  are  $+5.0V$ , linearity error typically will not change more than  $0.1$  LSB (see the curves in the Typical Electrical Characteristics Section). With the ADC set to an acquisition time of  $10$  clock periods, the

input biasing resistor needs to be  $600\Omega$  or less. Notice though that the input coupling capacitor needs to be made fairly large to bring down the high pass corner. Increasing the acquisition time to  $34$  clock periods (with a  $5$  MHz CCLK frequency) would allow the  $600\Omega$  to increase to  $6k$ , which with a  $1 \mu F$  coupling capacitor would set the high pass corner at  $26$  Hz. Increasing  $R_1$  to  $6k$  would allow  $R_2$  to be  $2k$ .

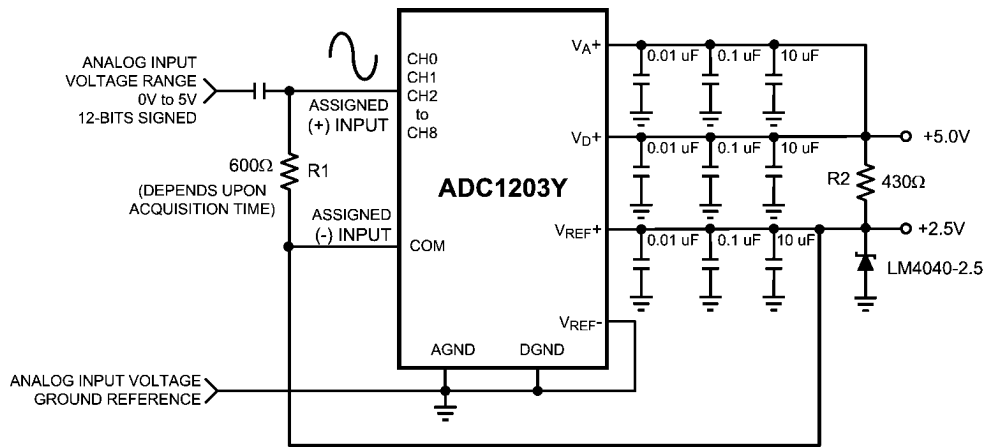

1135447

FIGURE 12. Pseudo-Differential Biasing with the Signal Source AC Coupled Directly into the ADC

An alternative method for biasing pseudo-differential operation is to use the  $+2.5V$  from the LM4040 to bias any amplifier circuits driving the ADC as shown in Figure 13. The value of the resistor pull-up biasing the LM4040-2.5 will depend upon the current required by the op amp biasing circuitry.

In the circuit of Figure 13, some voltage range is lost since the amplifier will not be able to swing to  $+5V$  and  $GND$  with a single  $+5V$  supply. Using an adjustable version of the LM4041

to set the full scale voltage at exactly  $2.048V$  and a lower grade LM4040D-2.5 to bias up everything to  $2.5V$  as shown in Figure 14 will allow the use of all the ADC's digital output range of  $-4096$  to  $+4095$  while leaving plenty of head room for the amplifier.

Fully differential operation is shown in Figure 15. One LSB for this case is equal to  $(4.1V/4096) = 1$  mV.

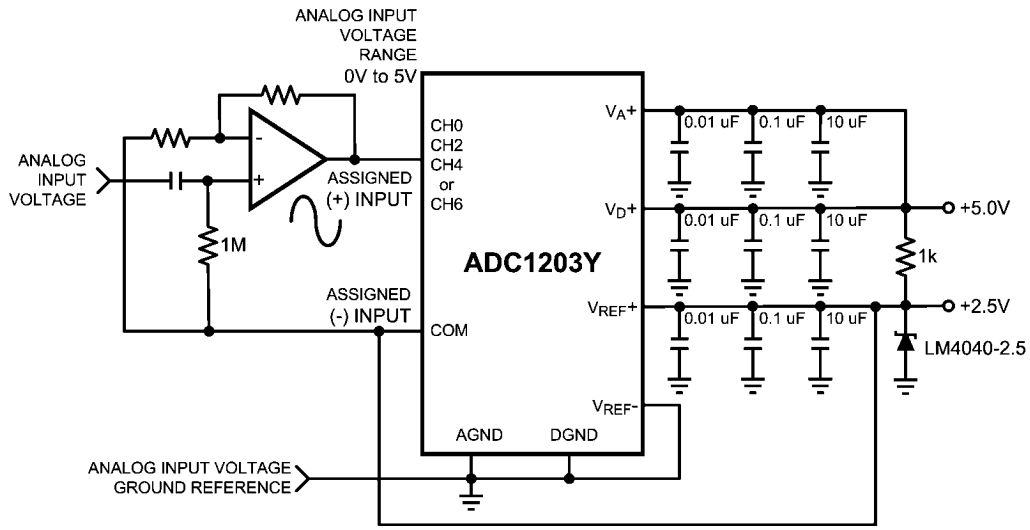

1135448

FIGURE 13. Alternative Pseudo-Differential Biasing

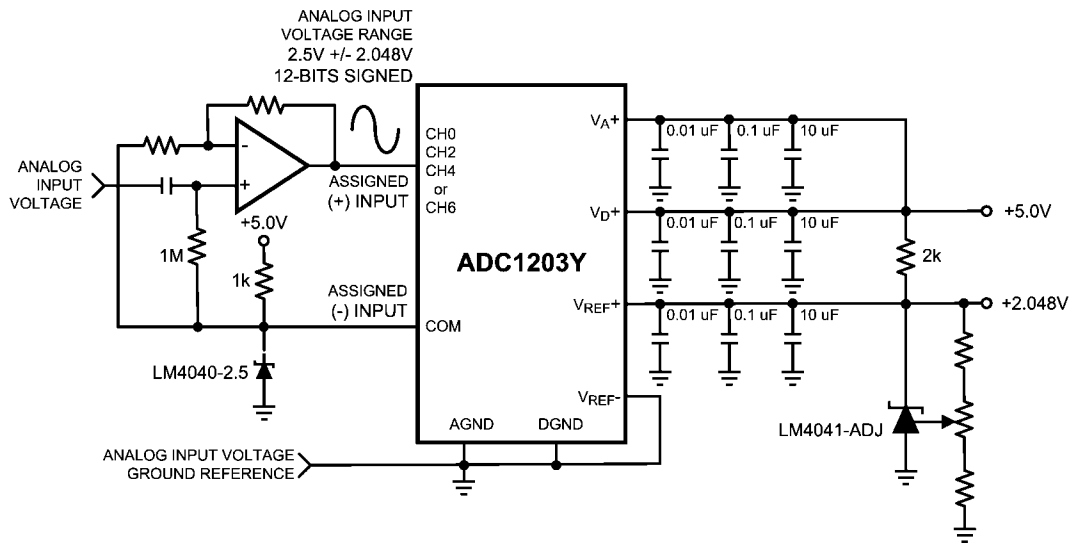

1135449

FIGURE 14. Pseudo-Differential Biasing without the Loss of Digital Output Range

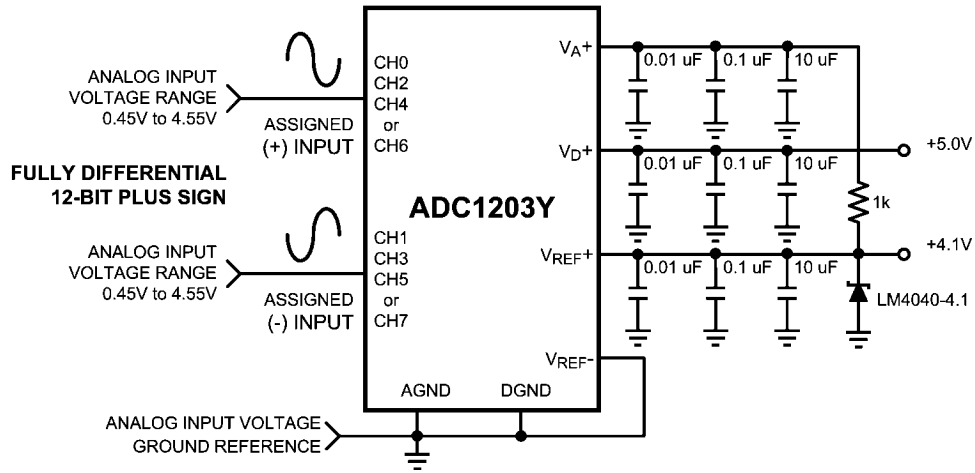

1135450

FIGURE 15. Fully Differential Biasing

3.0 REFERENCE VOLTAGE

The difference in the voltages applied to the  $V_{REF+}$  and  $V_{REF-}$  defines the analog input span (the difference between the voltage applied between two multiplexer inputs or the voltage applied to one of the multiplexer inputs and analog ground) over which 4095 positive and 4096 negative codes exist. The voltage sources driving  $V_{REF+}$  and  $V_{REF-}$  must have very low output impedance and noise. The circuit in is an example of a very stable reference appropriate for use with the device.

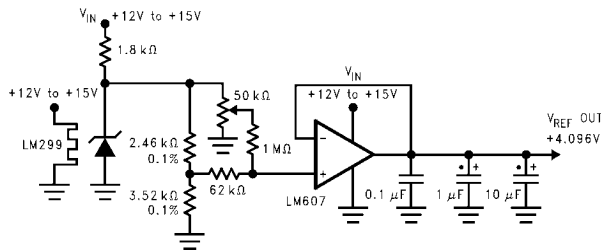

1135442

\*Tantalum

FIGURE 16. Low Drift Extremely Stable Reference Circuit

The ADC12030/2/4/8 can be used in either ratiometric or absolute reference applications. In ratiometric systems, the analog input voltage is proportional to the voltage used for the ADC's reference voltage. When this voltage is the system power supply, the  $V_{REF+}$  pin is connected to  $V_A+$  and  $V_{REF-}$  is connected to ground. This technique relaxes the system reference stability requirements because the analog input voltage and the ADC reference voltage move together. This maintains the same output code for given input conditions. For absolute accuracy, where the analog input voltage varies between very specific voltage limits, a time and temperature stable voltage source can be connected to the reference inputs. Typically, the reference voltage magnitude will require an initial adjustment to null reference voltage induced full-scale errors.

Below are recommended references along with some key specifications.

| Part Number          | Output Voltage Tolerance | Temperature Coefficient |
|----------------------|--------------------------|-------------------------|
| LM4041CI-Adj         | ±0.5%                    | ±100ppm/°C              |
| LM4040AI-4.1         | ±0.1%                    | ±100ppm/°C              |
| LM4120AI-4.1         | ±0.2%                    | ±50ppm/°C               |
| LM4121AI-4.1         | ±0.2%                    | ±50ppm/°C               |
| LM4050AI-4.1         | ±0.1%                    | ±50ppm/°C               |
| LM4030AI-4.1         | ±0.05%                   | ±10ppm/°C               |
| LM4140AC-4.1         | ±0.1%                    | ±3.0ppm/°C              |
| Circuit of Figure 16 | Adjustable               | ±2ppm/°C                |

The reference voltage inputs are not fully differential. The ADC12030/2/4/8 will not generate correct conversions or comparisons if  $V_{REF+}$  is taken below  $V_{REF-}$ . Correct conversions result when  $V_{REF+}$  and  $V_{REF-}$  differ by 1V or more and remain at all times between ground and  $V_A+$ . The  $V_{REF}$  common mode range,  $(V_{REF+} + V_{REF-})/2$ , is restricted to  $(0.1 \times V_A+)$  to  $(0.6 \times V_A+)$ . Therefore, with  $V_A+ = 5V$  the center of the reference ladder should not go below 0.5V or above 3.0V. Figure 17 is a graphic representation of the voltage restrictions on  $V_{REF+}$  and  $V_{REF-}$ .

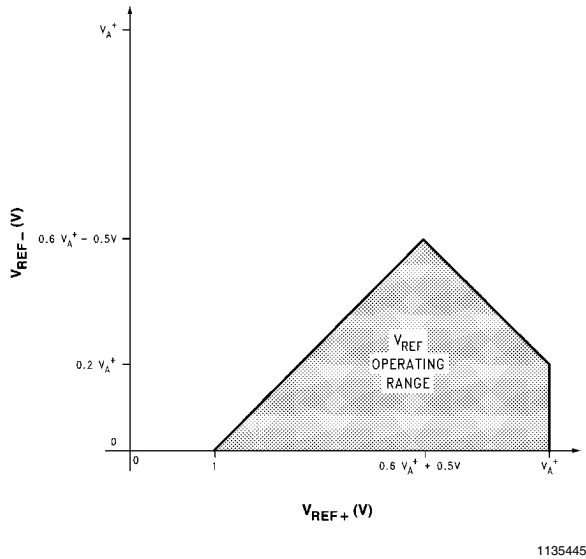

FIGURE 17. V<sub>REF</sub> Operating Range

**4.0 ANALOG INPUT VOLTAGE RANGE**

The ADC12030/2/4/8's fully differential ADC generate a two's complement output that is found by using the equations shown below:

for (12-bit) resolution the Output Code =

$$\frac{(V_{IN}^+ - V_{IN}^-) (4096)}{(V_{REF}^+ - V_{REF}^-)}$$

for (8-bit) resolution the Output Code =

$$\frac{(V_{IN}^+ - V_{IN}^-) (256)}{(V_{REF}^+ - V_{REF}^-)}$$

Round off to the nearest integer value between -4096 to 4095 for 12-bit resolution and between -256 to 255 for 8-bit resolution if the result of the above equation is not a whole number. Examples are shown in the table below:

| V <sub>REF</sub> <sup>+</sup> | V <sub>REF</sub> <sup>-</sup> | V <sub>IN</sub> <sup>+</sup> | V <sub>IN</sub> <sup>-</sup> | Digital Output Code |
|-------------------------------|-------------------------------|------------------------------|------------------------------|---------------------|
| +2.5V                         | +1V                           | +1.5V                        | 0V                           | 0,1111,1111,1111    |
| +4.096V                       | 0V                            | +3V                          | 0V                           | 0,1011,1011,1000    |
| +4.096V                       | 0V                            | +2.499V                      | +2.500V                      | 1,1111,1111,1111    |
| +4.096V                       | 0V                            | 0V                           | +4.096V                      | 1,0000,0000,0000    |

**5.0 INPUT CURRENT**

At the start of the acquisition window (t<sub>A</sub>) a charging current flows into or out of the analog input pins (A/DIN1 and A/DIN2) depending upon the input voltage polarity. The analog input pins are CH0-CH7 and COM when A/DIN1 is tied to MUXOUT1 and A/DIN2 is tied to MUXOUT2. The peak value of this input current will depend upon the actual input voltage applied, the source impedance and the internal multiplexer switch on resistance. With MUXOUT1 tied to A/DIN1 and MUXOUT2 tied to A/DIN2 the internal multiplexer switch on resistance is typically 1.6 kΩ. The A/DIN1 and A/DIN2 mux on resistance is typically 750Ω.

**6.0 INPUT SOURCE RESISTANCE**

For low impedance voltage sources (<600Ω), the input charging current will decay before the end of the S/H's acquisition time of 2 μs (10 CCLK periods with f<sub>C</sub> = 5 MHz), to a value that will not introduce any conversion errors. For high source impedances, the S/H's acquisition time can be increased to 18 or 34 CCLK periods. For less ADC resolution and/or slower CCLK frequencies the S/H's acquisition time may be decreased to 6 CCLK periods. To determine the number of clock periods (N<sub>C</sub>) required for the acquisition time with a specific source impedance for the various resolutions the following equations can be used:

12 Bit + Sign N<sub>C</sub> = [R<sub>S</sub> + 2.3] × f<sub>C</sub> × 0.824

8 Bit + Sign N<sub>C</sub> = [R<sub>S</sub> + 2.3] × f<sub>C</sub> × 0.57

Where f<sub>C</sub> is the conversion clock (CCLK) frequency in MHz and R<sub>S</sub> is the external source resistance in kΩ. As an example, operating with a resolution of 12 Bits+sign, a 5 MHz clock frequency and maximum acquisition time of 34 conversion clock periods the ADC's analog inputs can handle a source impedance as high as 6 kΩ. The acquisition time may also be extended to compensate for the settling or response time of external circuitry connected between the MUXOUT and A/DIN pins.

An acquisition starts at a falling edge of SCLK and ends at a rising edge of CCLK (see timing diagrams). If SCLK and CCLK are asynchronous, one extra CCLK clock period may be inserted into the programmed acquisition time for synchronization. Therefore, with asynchronous SCLK and CCLKs the acquisition time will change from conversion to conversion.

**7.0 INPUT BYPASS CAPACITANCE**

External capacitors (0.01 μF-0.1 μF) can be connected between the analog input pins, CH0-CH7, and analog ground to filter any noise caused by inductive pickup associated with long input leads. These capacitors will not degrade the conversion accuracy.

**8.0 NOISE**

The leads to each of the analog multiplexer input pins should be kept as short as possible. This will minimize input noise and clock frequency coupling that can cause conversion errors. Input filtering can be used to reduce the effects of the noise sources.

**9.0 POWER SUPPLIES**

Noise spikes on the V<sub>A</sub><sup>+</sup> and V<sub>D</sub><sup>+</sup> supply lines can cause conversion errors; the comparator will respond to the noise. The ADC is especially sensitive to any power supply spikes that occur during the Auto Zero or linearity correction. The minimum power supply bypassing capacitors recommended are low inductance tantalum capacitors of 10 μF or greater paralleled with 0.1 μF monolithic ceramic capacitors. More or different bypassing may be necessary depending upon the overall system requirements. Separate bypass capacitors should be used for the V<sub>A</sub><sup>+</sup> and V<sub>D</sub><sup>+</sup> supplies and placed as close as possible to these pins.

**10.0 GROUNDING**

The ADC12030/2/4/8's performance can be maximized through proper grounding techniques. These include the use of separate analog and digital areas of the board with analog and digital components and traces located only in their respective areas. Bypass capacitors of 0.01 μF and 0.1 μF surface mount capacitors and a 10 μF are recommended at each of the power supply pins for best performance. These

capacitors should be located as close to the bypassed pin as practical, especially the smaller value capacitors.

### 11.0 CLOCK SIGNAL LINE ISOLATION

The ADC12030/2/4/8's performance is optimized by routing the analog input/output and reference signal conductors as far as possible from the conductors that carry the clock signals to the CCLK and SCLK pins. Maintaining a separation of at least 7 to 10 times the height of the clock trace above its reference plane is recommended.

### 12.0 THE CALIBRATION CYCLE

A calibration cycle needs to be started after the power supplies, reference, and clock have been given enough time to stabilize after initial turn-on. During the calibration cycle, correction values are determined for the offset voltage of the sampled data comparator and any linearity and gain errors. These values are stored in internal RAM and used during an analog-to-digital conversion to bring the overall full-scale, offset, and linearity errors down to the specified limits. Full-scale error typically changes  $\pm 0.4$  LSB over temperature and linearity error changes even less; therefore it should be necessary to go through the calibration cycle only once after power up if the Power Supply Voltage and the ambient temperature do not change significantly (see the curves in the Typical Performance Characteristics).

### 13.0 THE Auto Zero CYCLE

To correct for any change in the zero (offset) error of the ADC, the Auto Zero cycle can be used. It may be necessary to do an Auto Zero cycle whenever the ambient temperature or the power supply voltage change significantly. (See the curves titled "Offset or Zero Error Change vs. Ambient Temperature" and "Offset or Zero Error Change vs. Supply Voltage" in the Typical Performance Characteristics.)

### 14.0 DYNAMIC PERFORMANCE

Many applications require the converter to digitize AC signals, but the standard DC integral and differential nonlinearity specifications will not accurately predict the ADC's performance with AC input signals. The important specifications for

AC applications reflect the converter's ability to digitize AC signals without significant spectral errors and without adding noise to the digitized signal. Dynamic characteristics such as signal-to-noise (S/N), signal-to-noise + distortion ratio (S/(N + D)), effective bits, full power bandwidth, aperture time and aperture jitter are quantitative measures of the ADC's capability.

An ADC's AC performance can be measured using Fast Fourier Transform (FFT) methods. A sinusoidal waveform is applied to the ADC's input, and the transform is then performed on the digitized waveform. S/(N + D) and S/N are calculated from the resulting FFT data, and a spectral plot may also be obtained. Typical values for S/N are shown in the table of Electrical Characteristics, and spectral plots of S/(N + D) are included in the typical performance curves.

The ADC's noise and distortion levels will change with the frequency of the input signal, with more distortion and noise occurring at higher signal frequencies. This can be seen in the S/(N + D) versus frequency curves.

Effective number of bits can also be useful in describing the ADC's noise and distortion performance. An ideal ADC will have some amount of quantization noise, determined by its resolution, and no distortion, which will yield an optimum S/(N + D) ratio given by the following equation:

$$S/(N + D) = (6.02 \times n + 1.76) \text{ dB}$$

where "n" is the ADC's resolution in bits.

The effective bits of an actual ADC is found to be:

$$n(\text{effective}) = \text{ENOB} = (S/(N + D) - 1.76) / 6.02$$

As an example, this device with a differential signed 5V, 1 kHz sine wave input signal will typically have a S/(N + D) of 77 dB, which is equivalent to 12.5 effective bits.

### 15.0 AN RS232 SERIAL INTERFACE

Shown on the following page is a schematic for an RS232 interface to any IBM and compatible PCs. The DTR, RTS, and CTS RS232 signal lines are buffered via level translators and connected to the ADC12038's DI, SCLK, and DO pins, respectively. The D flip flop drives the  $\overline{\text{CS}}$  control line.

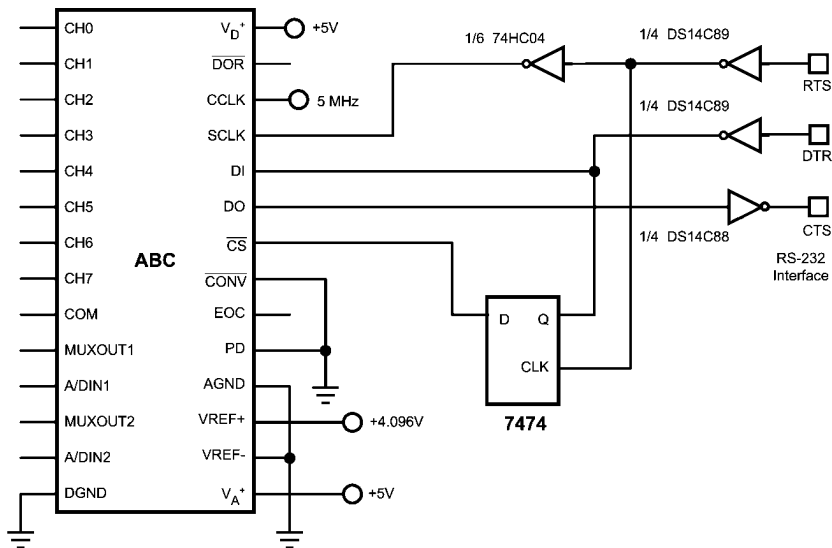

1135444

**Note:**  $V_{A+}$ ,  $V_{D+}$ , and  $V_{REF+}$  on the ADC12038 each have 0.01  $\mu\text{F}$  and 0.1  $\mu\text{F}$  chip caps, and 10  $\mu\text{F}$  tantalum caps. All logic devices are bypassed with 0.1  $\mu\text{F}$  caps.

The assignment of the RS-232 port is shown below

|      |                |     | B7 | B6 | B5 | B4  | B3 | B2 | B1  | B0  |
|------|----------------|-----|----|----|----|-----|----|----|-----|-----|
| COM1 | Input Address  | 3FE | X  | X  | X  | CTS | X  | X  | X   | X   |
|      | Output Address | 3FC | X  | X  | X  | 0   | X  | X  | RTS | DTR |

A sample program, written in Microsoft QuickBasic, is shown on the next page. The program prompts for data mode select instruction to be sent to the ADC. This can be found from the Mode Programming table shown earlier. The data should be entered in "1"s and "0"s as shown in the table with DIO first. Next, the program prompts for the number of SCLK cycles required for the programmed mode select instruction. For instance, to send all "0"s to the ADC, selects CH0 as the +input, CH1 as the -input, 12-bit conversion, and 13-bit MSB first data output format (if the sign bit was not turned off by a previous instruction). This would require 13 SCLK periods since the output data format is 13 bits.

The ADC powers up with No Auto Cal, No Auto Zero, 10 CCLK Acquisition Time, 12-bit conversion, data out with sign,

power up, 12- or 13-bit MSB first, and user mode. Auto Cal, Auto Zero, Power Up and Power Down instructions do not change these default settings. The following power up sequence should be followed:

1. Run the program
2. Prior to responding to the prompt apply the power to the ADC12038
3. Respond to the program prompts

It is recommended that the first instruction issued to the ADC12038 be Auto Cal (see *Section 1.1 Interface Concepts*).

## Code Listing:

```

'variables DOL=Data Out word length, DI=Data string for ADC DI input,
'
DO=ADC result string
'SET CS# HIGH
OUT &H3FC, (&H2 OR INP (&H3FC)) 'set RTS HIGH
OUT &H3FC, (&HFE AND INP(&H3FC)) 'set DTR LOW
OUT &H3FC, (&HFD AND INP(&H3FC)) 'set RTS LOW
OUT &H3FC, (&HEF AND INP(&H3FC)) 'set B4 low
10
LINE INPUT "DI data for ADC12038 (see Mode Table on data sheet)"; DI$
INPUT "ADC12038 output word length (8,9,12,13,16 or 17)"; DOL
20
'SET CS# HIGH
OUT &H3FC, (&H2 OR INP (&H3FC)) 'set RTS HIGH
OUT &H3FC, (&HFE AND INP(&H3FC)) 'set DTR LOW
OUT &H3FC, (&HFD AND INP(&H3FC)) 'set RTS LOW
'SET CS# LOW
OUT &H3FC, (&H2 OR INP (&H3FC)) 'set RTS HIGH
OUT &H3FC, (&H1 OR INP(&H3FC)) 'set DTR HIGH
OUT &H3FC, (&HFD AND INP(&H3FC)) 'set RTS LOW
DO$= " " 'reset DO variable
OUT &H3FC, (&H1 OR INP(&H3FC)) 'SET DTR HIGH
OUT &H3FC, (&HFD AND INP(&H3FC)) 'SCLK low
FOR N=1 TO 8
Temp$=MID$(DI$,N,1)
IF Temp$="0" THEN
OUT &H3FC, (&H1 OR INP(&H3FC))
ELSE OUT &H3FC, (&HFE AND INP(&H3FC))
END IF
OUT &H3FC, (&H2 OR INP(&H3FC)) 'out DI
IF (INP(&H3FE) AND 16)=16 THEN 'SCLK high
DO$=DO$+"0"
ELSE
DO$=DO$+"1"
END IF
OUT &H3FC, (&H1 OR INP(&H3FC)) 'input DO
OUT &H3FC, (&HFD AND INP(&H3FC)) 'SET DTR HIGH
OUT &H3FC, (&HFD AND INP(&H3FC)) 'SCLK low
NEXT N
IF DOL>8 THEN
FOR N=9 TO DOL
OUT &H3FC, (&H1 OR INP(&H3FC)) 'SET DTR HIGH
OUT &H3FC, (&HFD AND INP(&H3FC)) 'SCLK low
OUT &H3FC, (&H2 OR INP(&H3FC)) 'SCLK high
IF (INP(&H3FE) AND &H10)=&H10 THEN
DO$=DO$+"0"
ELSE
DO$=DO$+"1"
END IF
NEXT N
END IF
OUT &H3FC, (&HFA AND INP(&H3FC)) 'SCLK low and DI high
FOR N=1 TO 500
NEXT N
PRINT DO$
INPUT "Enter "C" to convert else "RETURN" to alter DI data"; s$
IF s$="C" OR s$="c" THEN
GOTO 20
ELSE
GOTO 10
END IF
END

```

**Physical Dimensions** inches (millimeters) unless otherwise noted

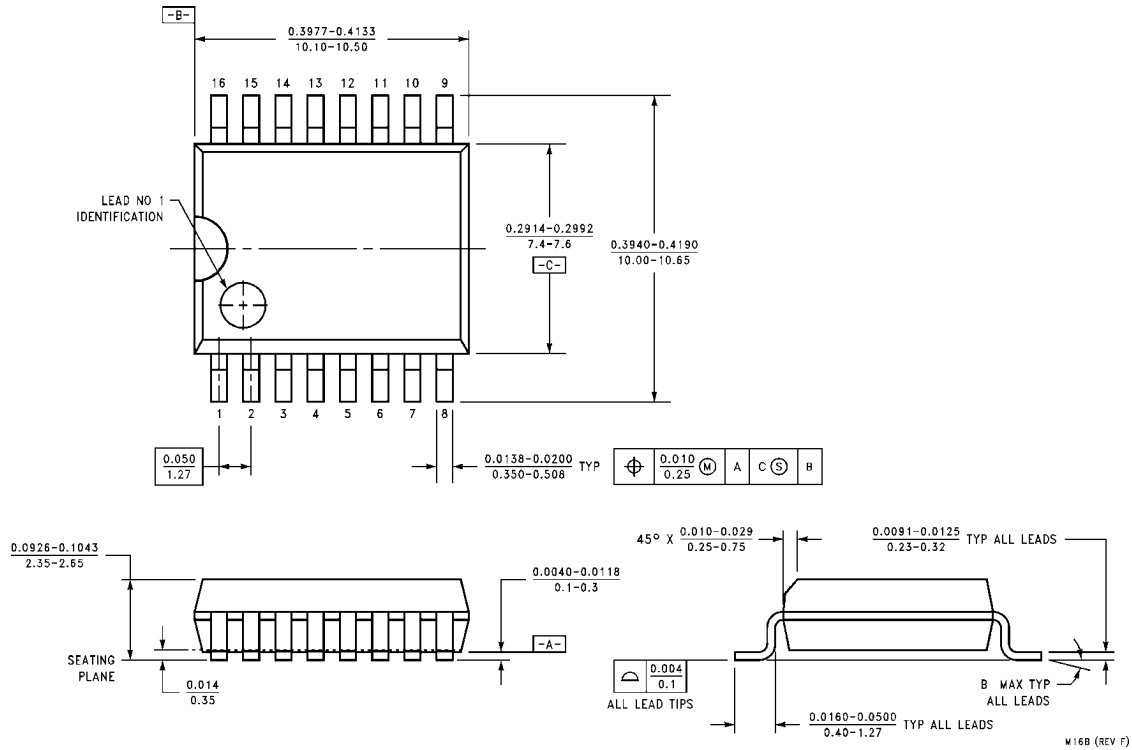

**Order Number ADC12030CIWM or ADC12H030CIWM**  
**NS Package Number M16B**

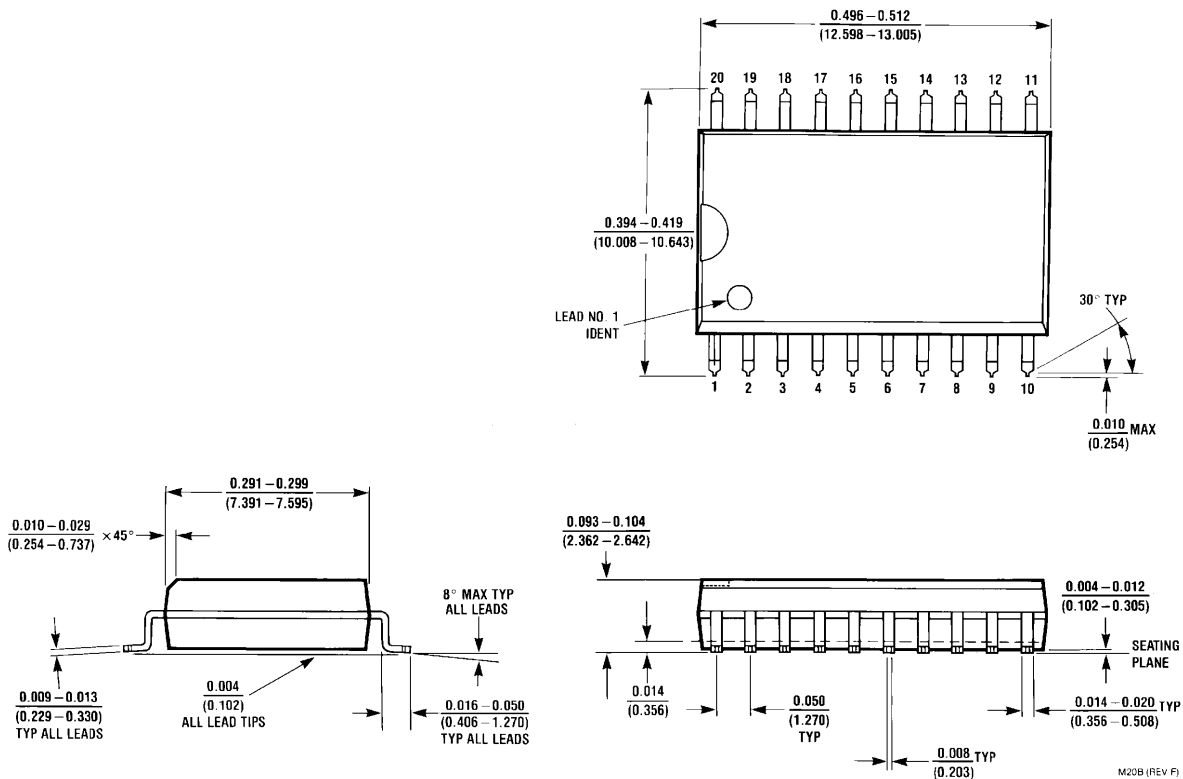

**Order Number ADC12032CIWM**  
**NS Package Number M20B**

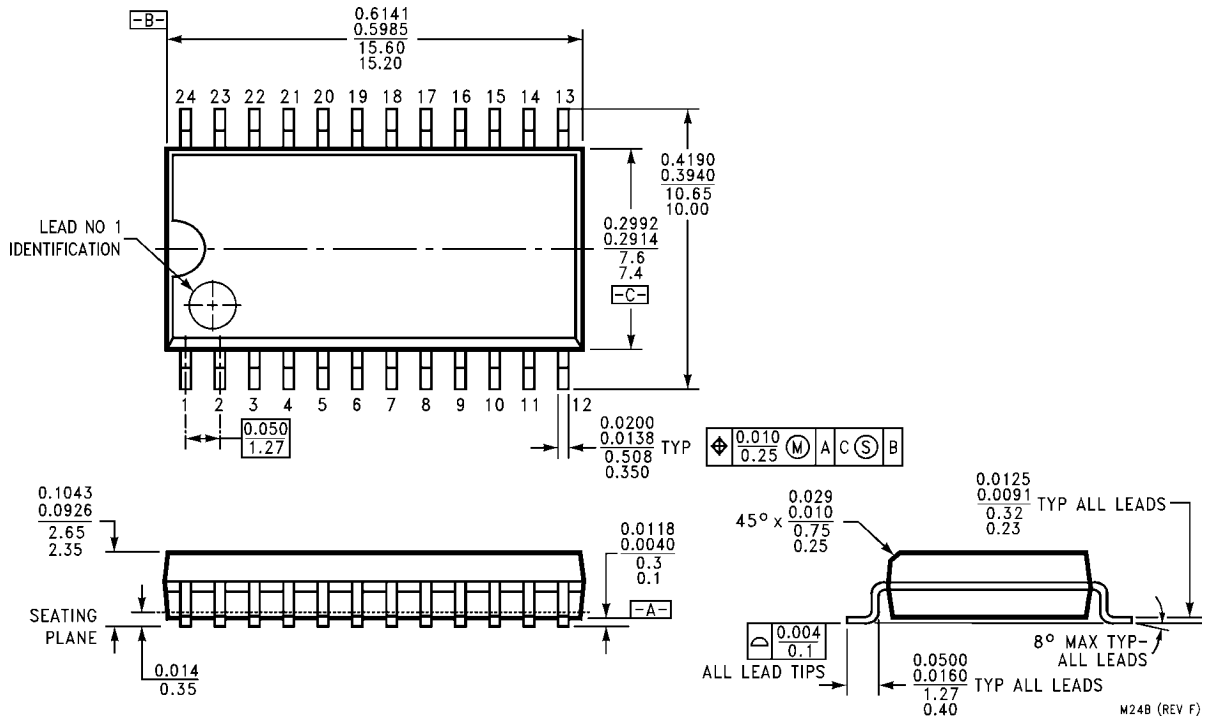

Order Number ADC12034CIWM  
NS Package Number M24B

M24B (REV F)

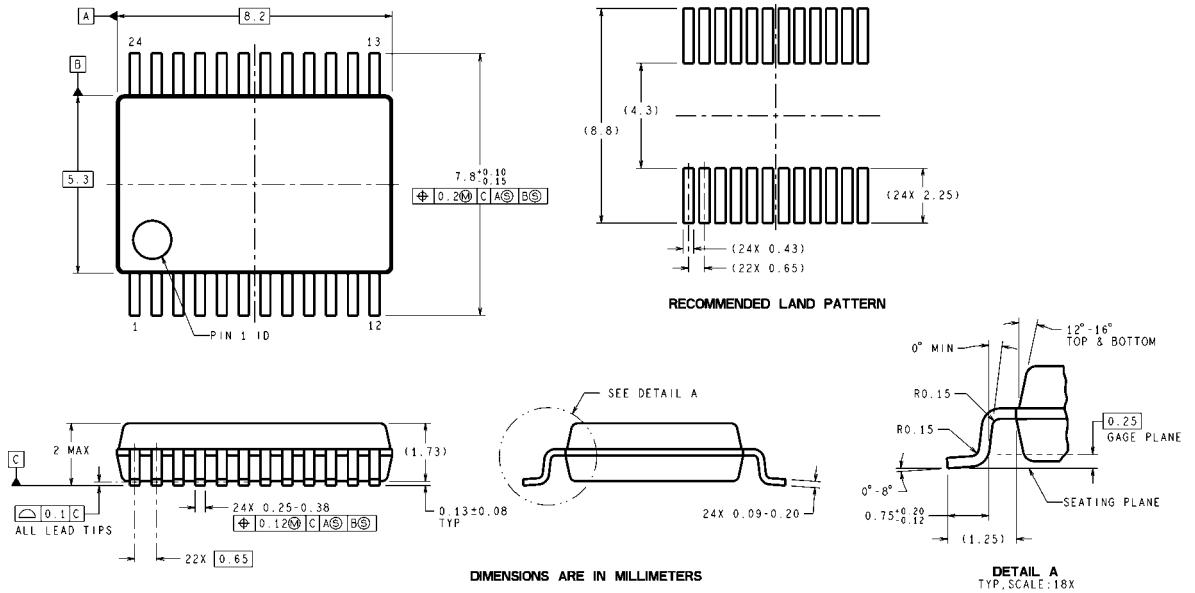

DIMENSIONS ARE IN MILLIMETERS

Order Number ADC12H034CIMS  
NS Package Number MSA24

MSA24 (Rev C)

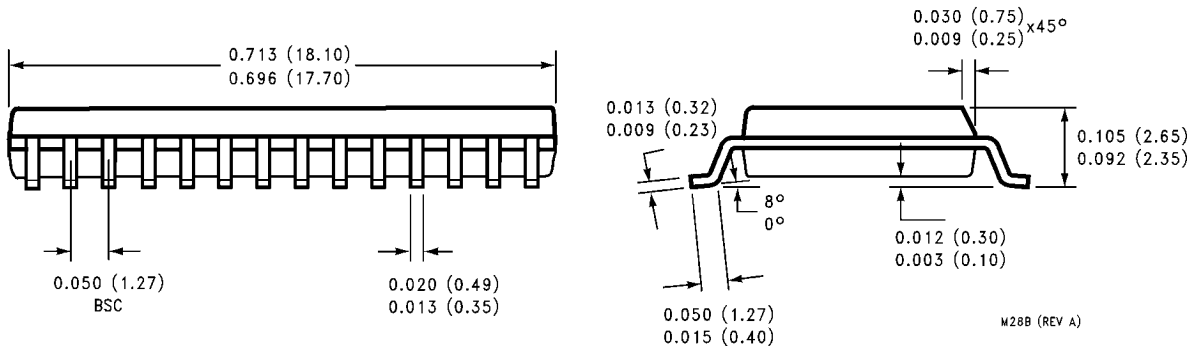
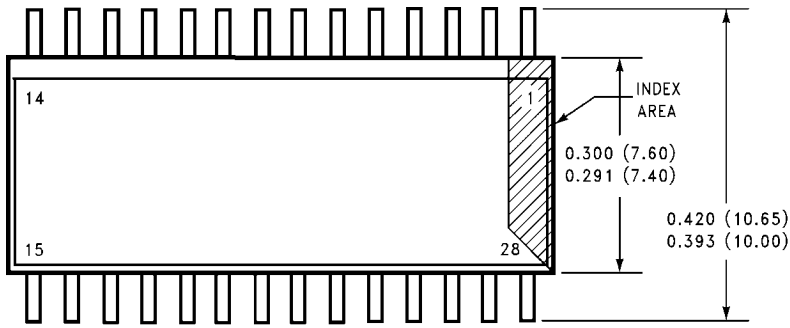

Order Number ADC12038CIWM or ADC12H038CIWM  
NS Package Number M28B

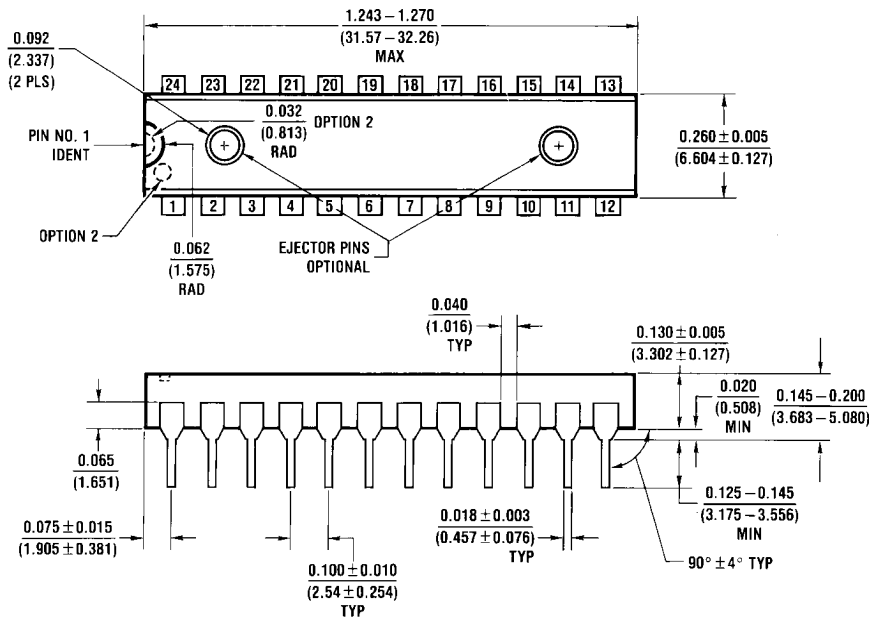

Order Number ADC12034CIN  
NS Package Number N24C

## Notes

For more National Semiconductor product information and proven design tools, visit the following Web sites at:

| Products                       |  | Design Support          |  |
|--------------------------------|--|-------------------------|--|
| Amplifiers                     | <a href="http://www.national.com/amplifiers">www.national.com/amplifiers</a>   | WEBENCH                 | <a href="http://www.national.com/webench">www.national.com/webench</a>             |
| Audio                          | <a href="http://www.national.com/audio">www.national.com/audio</a>             | Analog University       | <a href="http://www.national.com/AU">www.national.com/AU</a>                       |
| Clock Conditioners             | <a href="http://www.national.com/timing">www.national.com/timing</a>           | App Notes               | <a href="http://www.national.com/appnotes">www.national.com/appnotes</a>           |
| Data Converters                | <a href="http://www.national.com/adc">www.national.com/adc</a>                 | Distributors            | <a href="http://www.national.com/contacts">www.national.com/contacts</a>           |
| Displays                       | <a href="http://www.national.com/displays">www.national.com/displays</a>       | Green Compliance        | <a href="http://www.national.com/quality/green">www.national.com/quality/green</a> |
| Ethernet                       | <a href="http://www.national.com/ethernet">www.national.com/ethernet</a>       | Packaging               | <a href="http://www.national.com/packaging">www.national.com/packaging</a>         |
| Interface                      | <a href="http://www.national.com/interface">www.national.com/interface</a>     | Quality and Reliability | <a href="http://www.national.com/quality">www.national.com/quality</a>             |
| LVDS                           | <a href="http://www.national.com/lvds">www.national.com/lvds</a>               | Reference Designs       | <a href="http://www.national.com/refdesigns">www.national.com/refdesigns</a>       |
| Power Management               | <a href="http://www.national.com/power">www.national.com/power</a>             | Feedback                | <a href="http://www.national.com/feedback">www.national.com/feedback</a>           |
| Switching Regulators           | <a href="http://www.national.com/switchers">www.national.com/switchers</a>     |                         |  |
| LDOs                           | <a href="http://www.national.com/ldo">www.national.com/ldo</a>                 |                         |  |
| LED Lighting                   | <a href="http://www.national.com/led">www.national.com/led</a>                 |                         |  |
| PowerWise                      | <a href="http://www.national.com/powerwise">www.national.com/powerwise</a>     |                         |  |
| Serial Digital Interface (SDI) | <a href="http://www.national.com/sdi">www.national.com/sdi</a>                 |                         |  |
| Temperature Sensors            | <a href="http://www.national.com/tempsensors">www.national.com/tempsensors</a> |                         |  |
| Wireless (PLL/VCO)             | <a href="http://www.national.com/wireless">www.national.com/wireless</a>       |                         |  |

THE CONTENTS OF THIS DOCUMENT ARE PROVIDED IN CONNECTION WITH NATIONAL SEMICONDUCTOR CORPORATION ("NATIONAL") PRODUCTS. NATIONAL MAKES NO REPRESENTATIONS OR WARRANTIES WITH RESPECT TO THE ACCURACY OR COMPLETENESS OF THE CONTENTS OF THIS PUBLICATION AND RESERVES THE RIGHT TO MAKE CHANGES TO SPECIFICATIONS AND PRODUCT DESCRIPTIONS AT ANY TIME WITHOUT NOTICE. NO LICENSE, WHETHER EXPRESS, IMPLIED, ARISING BY ESTOPPEL OR OTHERWISE, TO ANY INTELLECTUAL PROPERTY RIGHTS IS GRANTED BY THIS DOCUMENT.

TESTING AND OTHER QUALITY CONTROLS ARE USED TO THE EXTENT NATIONAL DEEMS NECESSARY TO SUPPORT NATIONAL'S PRODUCT WARRANTY. EXCEPT WHERE MANDATED BY GOVERNMENT REQUIREMENTS, TESTING OF ALL PARAMETERS OF EACH PRODUCT IS NOT NECESSARILY PERFORMED. NATIONAL ASSUMES NO LIABILITY FOR APPLICATIONS ASSISTANCE OR BUYER PRODUCT DESIGN. BUYERS ARE RESPONSIBLE FOR THEIR PRODUCTS AND APPLICATIONS USING NATIONAL COMPONENTS. PRIOR TO USING OR DISTRIBUTING ANY PRODUCTS THAT INCLUDE NATIONAL COMPONENTS, BUYERS SHOULD PROVIDE ADEQUATE DESIGN, TESTING AND OPERATING SAFEGUARDS.

EXCEPT AS PROVIDED IN NATIONAL'S TERMS AND CONDITIONS OF SALE FOR SUCH PRODUCTS, NATIONAL ASSUMES NO LIABILITY WHATSOEVER, AND NATIONAL DISCLAIMS ANY EXPRESS OR IMPLIED WARRANTY RELATING TO THE SALE AND/OR USE OF NATIONAL PRODUCTS INCLUDING LIABILITY OR WARRANTIES RELATING TO FITNESS FOR A PARTICULAR PURPOSE, MERCHANTABILITY, OR INFRINGEMENT OF ANY PATENT, COPYRIGHT OR OTHER INTELLECTUAL PROPERTY RIGHT.

### LIFE SUPPORT POLICY

**NATIONAL'S PRODUCTS ARE NOT AUTHORIZED FOR USE AS CRITICAL COMPONENTS IN LIFE SUPPORT DEVICES OR SYSTEMS WITHOUT THE EXPRESS PRIOR WRITTEN APPROVAL OF THE CHIEF EXECUTIVE OFFICER AND GENERAL COUNSEL OF NATIONAL SEMICONDUCTOR CORPORATION.** As used herein:

Life support devices or systems are devices which (a) are intended for surgical implant into the body, or (b) support or sustain life and whose failure to perform when properly used in accordance with instructions for use provided in the labeling can be reasonably expected to result in a significant injury to the user. A critical component is any component in a life support device or system whose failure to perform can be reasonably expected to cause the failure of the life support device or system or to affect its safety or effectiveness.

National Semiconductor and the National Semiconductor logo are registered trademarks of National Semiconductor Corporation. All other brand or product names may be trademarks or registered trademarks of their respective holders.

Copyright© 2008 National Semiconductor Corporation

For the most current product information visit us at [www.national.com](http://www.national.com)



**National Semiconductor Americas Technical Support Center**  
Email: [support@nsc.com](mailto:support@nsc.com)  
Tel: 1-800-272-9959

**National Semiconductor Europe Technical Support Center**  
Email: [europe.support@nsc.com](mailto:europe.support@nsc.com)  
German Tel: +49 (0) 180 5010 771  
English Tel: +44 (0) 870 850 4288

**National Semiconductor Asia Pacific Technical Support Center**  
Email: [ap.support@nsc.com](mailto:ap.support@nsc.com)

**National Semiconductor Japan Technical Support Center**  
Email: [jpn.feedback@nsc.com](mailto:jpn.feedback@nsc.com)

## IMPORTANT NOTICE

Texas Instruments Incorporated and its subsidiaries (TI) reserve the right to make corrections, modifications, enhancements, improvements, and other changes to its products and services at any time and to discontinue any product or service without notice. Customers should obtain the latest relevant information before placing orders and should verify that such information is current and complete. All products are sold subject to TI's terms and conditions of sale supplied at the time of order acknowledgment.

TI warrants performance of its hardware products to the specifications applicable at the time of sale in accordance with TI's standard warranty. Testing and other quality control techniques are used to the extent TI deems necessary to support this warranty. Except where mandated by government requirements, testing of all parameters of each product is not necessarily performed.

TI assumes no liability for applications assistance or customer product design. Customers are responsible for their products and applications using TI components. To minimize the risks associated with customer products and applications, customers should provide adequate design and operating safeguards.

TI does not warrant or represent that any license, either express or implied, is granted under any TI patent right, copyright, mask work right, or other TI intellectual property right relating to any combination, machine, or process in which TI products or services are used. Information published by TI regarding third-party products or services does not constitute a license from TI to use such products or services or a warranty or endorsement thereof. Use of such information may require a license from a third party under the patents or other intellectual property of the third party, or a license from TI under the patents or other intellectual property of TI.

Reproduction of TI information in TI data books or data sheets is permissible only if reproduction is without alteration and is accompanied by all associated warranties, conditions, limitations, and notices. Reproduction of this information with alteration is an unfair and deceptive business practice. TI is not responsible or liable for such altered documentation. Information of third parties may be subject to additional restrictions.

Resale of TI products or services with statements different from or beyond the parameters stated by TI for that product or service voids all express and any implied warranties for the associated TI product or service and is an unfair and deceptive business practice. TI is not responsible or liable for any such statements.

TI products are not authorized for use in safety-critical applications (such as life support) where a failure of the TI product would reasonably be expected to cause severe personal injury or death, unless officers of the parties have executed an agreement specifically governing such use. Buyers represent that they have all necessary expertise in the safety and regulatory ramifications of their applications, and acknowledge and agree that they are solely responsible for all legal, regulatory and safety-related requirements concerning their products and any use of TI products in such safety-critical applications, notwithstanding any applications-related information or support that may be provided by TI. Further, Buyers must fully indemnify TI and its representatives against any damages arising out of the use of TI products in such safety-critical applications.

TI products are neither designed nor intended for use in military/aerospace applications or environments unless the TI products are specifically designated by TI as military-grade or "enhanced plastic." Only products designated by TI as military-grade meet military specifications. Buyers acknowledge and agree that any such use of TI products which TI has not designated as military-grade is solely at the Buyer's risk, and that they are solely responsible for compliance with all legal and regulatory requirements in connection with such use.

TI products are neither designed nor intended for use in automotive applications or environments unless the specific TI products are designated by TI as compliant with ISO/TS 16949 requirements. Buyers acknowledge and agree that, if they use any non-designated products in automotive applications, TI will not be responsible for any failure to meet such requirements.

Following are URLs where you can obtain information on other Texas Instruments products and application solutions:

### Products

|                        |  |
|------------------------|--|
| Audio                  | <a href="http://www.ti.com/audio">www.ti.com/audio</a>                               |
| Amplifiers             | <a href="http://amplifier.ti.com">amplifier.ti.com</a>                               |
| Data Converters        | <a href="http://dataconverter.ti.com">dataconverter.ti.com</a>                       |
| DLP® Products          | <a href="http://www.dlp.com">www.dlp.com</a>   |
| DSP                    | <a href="http://dsp.ti.com">dsp.ti.com</a>   |
| Clocks and Timers      | <a href="http://www.ti.com/clocks">www.ti.com/clocks</a>                             |
| Interface              | <a href="http://interface.ti.com">interface.ti.com</a>                               |
| Logic                  | <a href="http://logic.ti.com">logic.ti.com</a>                                       |
| Power Mgmt             | <a href="http://power.ti.com">power.ti.com</a>                                       |
| Microcontrollers       | <a href="http://microcontroller.ti.com">microcontroller.ti.com</a>                   |
| RFID                   | <a href="http://www.ti-rfid.com">www.ti-rfid.com</a>                                 |
| OMAP Mobile Processors | <a href="http://www.ti.com/omap">www.ti.com/omap</a>                                 |
| Wireless Connectivity  | <a href="http://www.ti.com/wirelessconnectivity">www.ti.com/wirelessconnectivity</a> |

### Applications

|                               |  |
|-------------------------------|--|
| Communications and Telecom    | <a href="http://www.ti.com/communications">www.ti.com/communications</a>                 |
| Computers and Peripherals     | <a href="http://www.ti.com/computers">www.ti.com/computers</a>                           |
| Consumer Electronics          | <a href="http://www.ti.com/consumer-apps">www.ti.com/consumer-apps</a>                   |
| Energy and Lighting           | <a href="http://www.ti.com/energy">www.ti.com/energy</a>                                 |
| Industrial                    | <a href="http://www.ti.com/industrial">www.ti.com/industrial</a>                         |
| Medical                       | <a href="http://www.ti.com/medical">www.ti.com/medical</a>                               |
| Security                      | <a href="http://www.ti.com/security">www.ti.com/security</a>                             |
| Space, Avionics and Defense   | <a href="http://www.ti.com/space-avionics-defense">www.ti.com/space-avionics-defense</a> |
| Transportation and Automotive | <a href="http://www.ti.com/automotive">www.ti.com/automotive</a>                         |
| Video and Imaging             | <a href="http://www.ti.com/video">www.ti.com/video</a>                                   |

TI E2E Community Home Page

[e2e.ti.com](http://e2e.ti.com)

Mailing Address: Texas Instruments, Post Office Box 655303, Dallas, Texas 75265  
Copyright © 2011, Texas Instruments Incorporated